**AUTHORIZED FEDERAL SUPPLY SERVICE INFORMATION TECHNOLOGY SCHEDULE
PRICELIST GENERAL PURPOSE COMMERCIAL INFORMATION TECHNOLOGY
EQUIPMENT, SOFTWARE AND SERVICES**

Training and Information Technology Professional Services

Special Item No. 132-51 Information Technology Professional Services

SPECIAL ITEM NUMBER 132-51 - INFORMATION TECHNOLOGY (IT) PROFESSIONAL SERVICES

| | |
|----------------|---------------------------------------------------------------------------------------------------------------------------------------------------------------------|
| FPDS Code D301 | IT Facility Operation and Maintenance |
| FPDS Code D302 | IT Systems Development Services |
| FPDS Code D306 | IT Systems Analysis Services |
| FPDS Code D307 | Automated Information Systems Design and Integration Services |
| FPDS Code D308 | Programming Services |
| FPDS Code D310 | IT Backup and Security Services |
| FPDS Code D311 | IT Data Conversion Services |
| FPDS Code D313 | Computer Aided Design/Computer Aided Manufacturing (CAD/CAM) Services |
| FPDS Code D316 | IT Network Management Services |
| FPDS Code D317 | Creation/Retrieval of IT Related Automated News Services, Data Services, or Other Information Services (All other information services belong under Schedule 76) |
| FPDS Code D399 | Other Information Technology Services, Not Elsewhere Classified |

Note 1: All non-professional labor categories must be incidental to and used solely to support hardware, software and/or professional services, and cannot be purchased separately.

Note 2: Offerors and Agencies are advised that the Group 70 – Information Technology Schedule is not to be used as a means to procure services which properly fall under the Brooks Act. These services include, but are not limited to, architectural, engineering, mapping, cartographic production, remote sensing, geographic information systems, and related services. FAR 36.6 distinguishes between mapping services of an A/E nature and mapping services which are not connected nor incidental to the traditionally accepted A/E Services.

Note 3: This solicitation is not intended to solicit for the reselling of IT Professional Services, except for the provision of implementation, maintenance, integration, or training services in direct support of a product. Under such circumstances the services must be performance by the publisher or manufacturer or one of their authorized agents.

Digitized Schematic Solutions, LLC
40 W. Cochran Street #212
Simi Valley, CA 93065
818-889-1136
www.digitizedschematic.com

Contract Number: GS-35F-0570X

Period Covered by Contract: August 29, 2011 through August 28, 2016

General Services Administration Federal Acquisition Service

Pricelist current through Modification #PO-0006, dated 03/29/2012.

Products and ordering information in this Authorized FSS Information Technology Schedule Pricelist are also available on the GSA Advantage! System (<http://www.gsaadvantage.gov>).

Table of Contents

| Section | Page |
|-------------------------------------------------------------------------------------------|------|
| Corporate Information | |
| Corporate Overview | 4 |
| Expertise and Capabilities | 4 |
| Information Technologies Professional Services | |
| DST | 5 |
| p2Trace™ | 5 |
| p2Sim™ | 5 |
| Information For Ordering Activities | |
| 1. Geographic Scope of Contract | 7 |
| 2. Ordering Addressing and Payment Information | 8 |
| 3. Liability for Injury or Damage | 8 |
| 4. Statistical Data for Government Ordering Office Competition of Standard Form 279 | 8 |
| 5. F.O.B. Destination | 8 |
| 6. Delivery Schedule | 8 |
| 7. Discounts | 9 |
| 8. Trade Agreements Act of 1979 | 9 |
| 9. Statement Concerning Availability of Export Packing | 9 |
| 10. Small Requirements | 9 |
| 11. Maximum Order | 9 |
| 12. Ordering Procedures for Federal Supply Schedule Contracts | 9 |
| 13. Federal Information Technology/Telecommunications Standards Requirements | 10 |
| 14. Contractor Tasks/Special Requirements (C-FSS-370) (Nov 2001) | 10 |
| 15. Contract Administration for Ordering Activities | 11 |
| 16. GSA Advantage | 12 |
| 17. Purchase of Open Market Items | 12 |
| 18. Contract Commitments, Warranties and Representations | 12 |
| 19. Overseas Activities | 13 |
| 20. Blanket Purchase Agreements | 13 |
| 21. Contractor Team Arrangements | 13 |
| 22. Installation, Deinstallation, Reinstallation | 13 |
| 23. Section 508 Compliance | 14 |
| 24. Prime Contractor Ordering From Federal Supply Schedule | 14 |
| 25. Insurance-Work on a Government Installation (Jan 1997) (FAR 52.228-5) | 14 |
| 26. Software Interoperability | 14 |
| 27. Advance Payments | 15 |
| Terms and Conditions | |
| SIN 132-51 Information Technology Professional Services | 16 |

Labor Categories & Pricing

| | |
|---------------------------------------|----|
| Labor Categories & Descriptions | 20 |
| Government Price List | 22 |

USA Commitment to Promote Small Business Procurement Programs

| | |
|------------------|----|
| Preamble..... | 23 |
| Commitment | 23 |

Blanket Purchase Agreements (BPAs)

| | |
|--------------------------------------------------------------------|----|
| Best Value Blanket Purchase Agreement Federal Supply Schedule..... | 24 |
|--------------------------------------------------------------------|----|

Contractor Team Arrangements

| | |
|-----------------------------------------------------------------|----|
| Basic Guidelines for Using “Contractor Team Arrangements” | 27 |
|-----------------------------------------------------------------|----|

Digitized Schematic Solutions LLC Corporate Background

Corporate Overview

Digitized Schematic Solutions (DSS) LLC is a small, disadvantaged, wholly-owned subsidiary of Koniag Development Corporation, a native American-owned Corporation headquartered in Anchorage, Alaska with developmental facilities in Simi Valley, CA. DSS is also certified as a participant in the U.S. Small Business Administration's (SBA) 8(a) Business Development Program. DSS is a recognized leader and pioneer in the design and development of the Digital Schematic Tool (DST) which incorporates the p2Trace™ and p2Sim™ Point to Point Wiring & Signal Tracing technologies. Our design and developmental staff includes Electrical, Hydraulic and Pneumatic Engineering, Computer Programmers and Multimedia Developers. Our current customer set includes elements of the U.S. Air Force, U.S. Marine Corps, U.S. Army, U.S. Navy and commercial Original Equipment Manufacturers (OEMs).

Expertise and Capabilities

DSS's products and services include: The Digital Schematic Tool (DST) which combines both the p2Trace™ and p2Sim™ Point to Point Wiring & Signal Tracing technologies.

Digital Schematic Tool (DST): Our current core business emphasis is the design and development of the DST which is a custom-designed software technology which introduces intelligence to OEM electrical, hydraulic, pneumatic and fluid flow schematics and drawings and which significantly enhance both maintenance troubleshooting and training disciplines. The DST is comprised of two separate, but very distinct applications commonly referred to as p2Trace™ and p2Sim™ Point to Point Wiring & Signal Tracing.

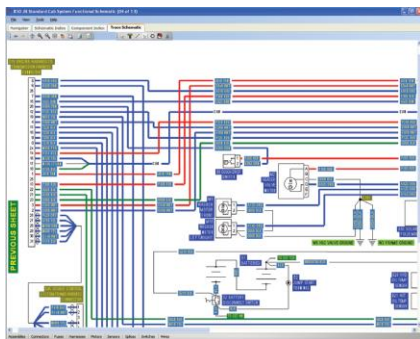

The **p2Trace™** application is a fully interactive, Computer Graphic Metafile (CGM) Level 4 replica of the OEM schematic drawings which are thoroughly analyzed by our professional electronic and mechanical engineering staff and then programmed into a Relational Database Management Systems (RDBMS) for ready access by a maintainer/technician. This state-of-the-art technology enables the maintainer/technician to effectively troubleshoot all of the wiring, cabling, backplane harnesses and electro-mechanical interfaces associated with any system.

The **p2Sim™** application is a fully interactive, emulation of all circuitry associated with a specific system function (e.g., master power). It is designed for maintainers by maintainers to impart their professional knowledge of how complex circuitry reacts under varying, selectable conditions. This custom-designed technology insertion is extremely effective both on the job as a troubleshooting / training tool and in the traditional classroom as a high quality teaching aid.

When these two applications are integrated as a common

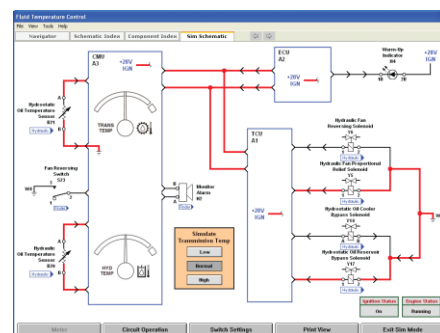

package, a troubleshooting/training tool becomes available to the maintainer/trainer that is second to none. Reductions in Mean Time to Repair (MTTR) of up to 40%+ are achievable through the use of these combined troubleshooting / training applications.

Digitized Schematic Solutions LLC Information Technology Professional Services

Information Technology (IT) Professional Services
DSS offers the following services to its clients:

Digital Schematic Tool (DST) Development:

Digitized Schematic Solutions (DSS) LLC will design and develop a customized Digital Schematic Tool (DST) viewer with selectable pull-down menus to enable the user instant access to all available data including specific schematics or components. Note: There are no recurring run time or licensing fees associated with the DST software application.

p2Trace™ Development:

DSS will process all customer provided schematics to be accessed and used within the TraceMode selection of DST. The p2Trace™ application is primarily designed to assist and guide both the expert and novice maintainer / technician in understanding how a selected circuit was designed, as well as provide a fully interactive data source to assist in accomplishing effective troubleshooting and maintenance procedures.

The p2Trace™ application initially takes the Original Equipment Manufacturers (OEM) provided schematic data and converts it from its current source (e.g., paper, .pdf, CAD, etc) into an intelligent Computer Graphic Metafile (CGM) Level 4, intelligent format without making any changes whatsoever to the original source data, after which a comprehensive data base management system (e.g., MS Access, Oracle, etc) is custom designed to accept all of the associated schematic meta data. The schematics are then professionally analyzed by a staff of electrical, hydraulic and pneumatic engineers and all wires are initially assigned a default color (e.g., Red – Power / Blue – Signals / Green – Grounds) and all hoses, connectors, etc. are cataloged for entry into the database, The schematic may be cosmetically colorized to identify functionally associated areas, if desired. Fully interactive sheet links are developed to ensure continuity of a selected circuit continues uninterrupted from start-to- finish without any loss of functionality. Fully interactive, sort capable listings of all system components, schematic sheets, reference designators, wire lists and all other associated meta data are then incorporated into the data base for instant recall. A fully interactive Help and retrievable History file is custom developed to support the p2Trace™ application. Hyperlinks to/from associated p2Sim™ depictions or other external meta-data provided are included in the data base, as applicable.

p2Sim™ Development:

DSS will design and develop fully interactive, discrete circuits to be accessed and used within the Sim Mode selection of DST.

The p2Sim™ application is primarily designed to assist and guide the novice maintainer /

technician in the basic understanding of the selected circuit, as well as provide an excellent data source for the development of a Plan of Instruction (POI) to support the traditional classroom or OJT environments.

p2Sim™ segregates individual circuitry into “function specific” diagrams (e.g., master power, lights, etc). All applicable circuitry is then extracted from the master schematic, analyzed by the engineering staff and then redrawn into a single screen depiction, or series of screen depictions, of the selected circuit functions. All associated circuit functionality is readily accessible through hyperlinks to all related and otherwise supported circuits. High-end multi-media (e.g., colorization, animation, audio, video, 3D, etc., as applicable) is then applied throughout the p2Sim™ application to provide the user with a complete understanding of how a circuit functions under various selectable conditions. Every applicable switch, circuit breaker, etc., on the drawing is fully interactive. A non-intrusive, fully interactive meter function (voltage, amperage, fluid flow) is provided, as applicable, which depicts the technical order / manual directed values expected under the selected operation. A fully interactive relay finder is also provided. A common viewer menu presents selected component theory, component location, animations when applicable and hyper links to other applications (e.g., p2Trace™, IETM / IETP / ETM), when applicable. Overall circuit theory operation is presented as well as a full print capability of individual screen shots. A custom developed interactive, multimedia driven tutorial style Help file and retrievable History capability contributes to the overall effectiveness of application. Hyperlinks to/from associated p2Trace™ schematics or other external meta-data provided are included in the data base, as applicable.

INFORMATION FOR ORDERING ACTIVITIES APPLICABLE TO ALL SPECIAL ITEM NUMBERS

SPECIAL NOTICE TO AGENCIES: Small Business Participation

The Small Business Administration (SBA) strongly supports the participation of small business concerns in the Federal Acquisition Service. To enhance Small Business Participation SBA policy allows agencies to include in their procurement base and goals, the dollar value of orders expected to be placed against the Federal Supply Schedules, and to report accomplishments against these goals.

For orders exceeding the micropurchase threshold, FAR 8.404 requires agencies to consider the catalogs/pricelists of at least three schedule contractors or consider reasonably available information by using the GSA Advantage!™ on-line shopping service (www.gsaadvantage.gov). The catalogs/pricelists, GSA Advantage!™ and the Federal Acquisition Service Home Page (www.fss.gsa.gov) contain information on a broad array of products and services offered by small business concerns.

This information should be used as a tool to assist ordering activities in meeting or exceeding established small business goals. It should also be used as a tool to assist in including small, small disadvantaged, and women-owned small businesses among those considered when selecting pricelists for a best value determination.

For orders exceeding the micropurchase threshold, customers are to give preference to small business concerns when two or more items at the same delivered price will satisfy their requirement.

1. GEOGRAPHIC SCOPE OF CONTRACT:

Domestic delivery is delivery within the 48 contiguous states, Alaska, Hawaii, Puerto Rico, Washington, DC, and U.S. Territories. Domestic delivery also includes a port or consolidation point, within the aforementioned areas, for orders received from overseas activities.

Overseas delivery is delivery to points outside of the 48 contiguous states, Washington, DC, Alaska, Hawaii, Puerto Rico, and U.S. Territories.

Offerors are requested to check one of the following boxes:

- The Geographic Scope of Contract will be domestic and overseas delivery.
- The Geographic Scope of Contract will be overseas delivery only.
- The Geographic Scope of Contract will be domestic delivery only.

For Special Item Number 132-53 Wireless Services ONLY, if awarded, list the limited geographic coverage area:

2. CONTRACTOR'S ORDERING ADDRESS AND PAYMENT INFORMATION:

31416 Agoura Road, Suite 140

Contractor must accept the credit card for payments equal to or less than the micro-purchase for oral or written orders under this contract. Credit card will be accepted for dollar amounts over the micro-purchase threshold (See GSAR 552.232-79 Payment by Credit Card). In addition, bank account information for wire transfer payments will be shown on the invoice.

The following telephone number(s) can be used by ordering activities to obtain technical and/or ordering assistance:

818-889-1136 x101

3. LIABILITY FOR INJURY OR DAMAGE

The Contractor shall not be liable for any injury to ordering activity personnel or damage to ordering activity property arising from the use of equipment maintained by the Contractor, unless such injury or damage is due to the fault or negligence of the Contractor.

4. STATISTICAL DATA FOR GOVERNMENT ORDERING OFFICE COMPLETION OF STANDARD FORM 279:

Block 9: G. Order/Modification Under Federal Schedule

Block 16: Data Universal Numbering System (DUNS) Number: 963249599

Block 30: Type of Contractor - B. Other Small Business

Block 31: Woman-Owned Small Business – No

Block 36: Contractor's Taxpayer Identification Number (TIN): 272924315

Block 40: Veteran Owned Small Business (VOSB): No

4a. **CAGE Code:** 62KDI

4b. **Contractor has registered with the Central Contractor Registration Database.**

5. FOB DESTINATION

6. DELIVERY SCHEDULE

a. **TIME OF DELIVERY:** The Contractor shall deliver to destination within the number of calendar days after receipt of order (ARO), as set forth below:

SPECIAL ITEM NUMBER

DELIVERY TIME (Days ARO)

| | |
|--------|----------------------------------------------------------------|
| 132-51 | As Negotiated between the Contractor and the Ordering Activity |
|--------|----------------------------------------------------------------|

b. **URGENT REQUIREMENTS:** When the Federal Supply Schedule contract delivery period does not meet the bona fide urgent delivery requirements of an ordering activity, ordering activities are encouraged, if time permits, to contact the Contractor for the purpose of obtaining accelerated delivery. The Contractor shall reply to the inquiry within 3 workdays after receipt. (Telephonic replies shall be confirmed by the Contractor in writing.) If the Contractor offers an accelerated delivery time acceptable to the ordering activity, any order(s) placed pursuant to the agreed upon accelerated delivery time frame shall be delivered within this shorter delivery time and in accordance with all other terms and conditions of the contract.

7. **DISCOUNTS:** Prices shown are NET Prices; Basic Discounts have been deducted.

- a. Prompt Payment: None.
- b. Quantity - No
- c. Dollar Volume - None.
- d. Government Educational Institutions - Offered the same as GSA discounts.
- e. Other

8. **TRADE AGREEMENTS ACT OF 1979, as amended:**

All items are U.S. made end products, designated country end products, Caribbean Basin country end products, Canadian end products, or Mexican end products as defined in the Trade Agreements Act of 1979, as amended.

9. **STATEMENT CONCERNING AVAILABILITY OF EXPORT PACKING:**

Not available under scope of this contract.

10. **Small Requirements:** The minimum dollar value of orders to be issued is \$100.00.

11. **MAXIMUM ORDER (All dollar amounts are exclusive of any discount for prompt payment.)**

- a. The Maximum Order value for the following Special Item Number (SINs) is \$500,000:
Special Item Number 132-51 Information Technology Professional Services

12. **ORDERING PROCEDURES FOR FEDERAL SUPPLY SCHEDULE CONTRACTS**

Ordering activities shall use the ordering procedures of Federal Acquisition Regulation (FAR) 8.405 when placing an order or establishing a BPA for supplies or services. These procedures apply to all schedules.

- a. FAR 8.405-1 Ordering procedures for supplies, and services not requiring a statement of work.
- b. FAR 8.405-2 Ordering procedures for services requiring a statement of work.

13. FEDERAL INFORMATION TECHNOLOGY/TELECOMMUNICATION STANDARDS

REQUIREMENTS: ordering activities acquiring products from this Schedule must comply with the provisions of the Federal Standards Program, as appropriate (reference: NIST Federal Standards Index). Inquiries to determine whether or not specific products listed herein comply with Federal Information Processing Standards (FIPS) or Federal Telecommunication Standards (FED-STDS), which are cited by ordering activities, shall be responded to promptly by the Contractor.

13.1 FEDERAL INFORMATION PROCESSING STANDARDS PUBLICATIONS (FIPS

PUBS): Information Technology products under this Schedule that do not conform to Federal Information Processing Standards (FIPS) should not be acquired unless a waiver has been granted in accordance with the applicable "FIPS Publication." Federal Information Processing Standards Publications (FIPS PUBS) are issued by the U.S. Department of Commerce, National Institute of Standards and Technology (NIST), pursuant to National Security Act. Information concerning their availability and applicability should be obtained from the National Technical Information Service (NTIS), 5285 Port Royal Road, Springfield, Virginia 22161. FIPS PUBS include voluntary standards when these are adopted for Federal use. Individual orders for FIPS PUBS should be referred to the NTIS Sales Office, and orders for subscription service should be referred to the NTIS Subscription Officer, both at the above address, or telephone number (703) 487-4650.

13.2 FEDERAL TELECOMMUNICATION STANDARDS (FED-STDS): Telecommunication products under this Schedule that do not conform to Federal Telecommunication Standards (FED-STDS) should not be acquired unless a waiver has been granted in accordance with the applicable "FED-STD." Federal Telecommunication Standards are issued by the U.S. Department of Commerce, National Institute of Standards and Technology (NIST), pursuant to National Security Act. Ordering information and information concerning the availability of FED-STDS should be obtained from the GSA, Federal Acquisition Service, Specification Section, 470 East L'Enfant Plaza, Suite 8100, SW, Washington, DC 20407, telephone number (202)619-8925. Please include a self-addressed mailing label when requesting information by mail. Information concerning their applicability can be obtained by writing or calling the U.S. Department of Commerce, National Institute of Standards and Technology, Gaithersburg, MD 20899, telephone number (301)975-2833.

14. CONTRACTOR TASKS / SPECIAL REQUIREMENTS (C-FSS-370) (NOV 2003)

- (a) **Security Clearances:** The Contractor may be required to obtain/possess varying levels of security clearances in the performance of orders issued under this contract. All costs associated with obtaining/possessing such security clearances should be factored into the price offered under the Multiple Award Schedule.
- (b) **Travel:** The Contractor may be required to travel in performance of orders issued under this contract. Allowable travel and per diem charges are governed by Pub .L. 99-234 and FAR Part 31, and are reimbursable by the ordering agency or can be priced as a fixed price item on orders placed under the Multiple Award Schedule. Travel in performance of a task order will only be reimbursable to the extent authorized by the ordering agency. The Industrial Funding Fee does NOT apply to travel and per diem charges.

- (c) **Certifications, Licenses and Accreditations:** As a commercial practice, the Contractor may be required to obtain/possess any variety of certifications, licenses and accreditations for specific FSC/service code classifications offered. All costs associated with obtaining/possessing such certifications, licenses and accreditations should be factored into the price offered under the Multiple Award Schedule program.
- (d) **Insurance:** As a commercial practice, the Contractor may be required to obtain/possess insurance coverage for specific FSC/service code classifications offered. All costs associated with obtaining/possessing such insurance should be factored into the price offered under the Multiple Award Schedule program.
- (e) **Personnel:** The Contractor may be required to provide key personnel, resumes or skill category descriptions in the performance of orders issued under this contract. Ordering activities may require agency approval of additions or replacements to key personnel.
- (f) **Organizational Conflicts of Interest:** Where there may be an organizational conflict of interest as determined by the ordering agency, the Contractor's participation in such order may be restricted in accordance with FAR Part 9.5.
- (g) **Documentation/Standards:** The Contractor may be requested to provide products or services in accordance with rules, regulations, OMB orders, standards and documentation as specified by the agency's order.
- (h) **Data/Deliverable Requirements:** Any required data/deliverables at the ordering level will be as specified or negotiated in the agency's order.
- (i) **Government-Furnished Property:** As specified by the agency's order, the Government may provide property, equipment, materials or resources as necessary.
- (j) **Availability of Funds:** Many Government agencies' operating funds are appropriated for a specific fiscal year. Funds may not be presently available for any orders placed under the contract or any option year. The Government's obligation on orders placed under this contract is contingent upon the availability of appropriated funds from which payment for ordering purposes can be made. No legal liability on the part of the Government for any payment may arise until funds are available to the ordering Contracting Officer.
- (k) **Overtime:** For professional services, the labor rates in the Schedule should not vary by virtue of the Contractor having worked overtime. For services applicable to the Service Contract Act (as identified in the Schedule), the labor rates in the Schedule will vary as governed by labor laws (usually assessed a time and a half of the labor rate).

15. CONTRACT ADMINISTRATION FOR ORDERING ACTIVITIES: Any ordering activity, with respect to any one or more delivery orders placed by it under this contract, may exercise the same rights of termination as might the GSA Contracting Officer under provisions of FAR 52.212-4, paragraphs (l) Termination for the ordering activity's convenience, and (m) Termination for Cause (See 52.212-4)

16. GSA ADVANTAGE!

GSA Advantage! is an on-line, interactive electronic information and ordering system that provides on-line access to vendors' schedule prices with ordering information. GSA Advantage! will allow the user to perform various searches across all contracts including, but not limited to:

- (1) Manufacturer;
- (2) Manufacturer's Part Number; and
- (3) Product categories.

Agencies can browse GSA Advantage! by accessing the Internet World Wide Web utilizing a browser (ex.: NetScape). The Internet address is <http://www.gsadvantage.gov>

17. PURCHASE OF OPEN MARKET ITEMS

NOTE: Open Market Items are also known as incidental items, noncontract items, non-Schedule items, and items not on a Federal Supply Schedule contract. ODCs (Other Direct Costs) are not part of this contract and should be treated as open market purchases. Ordering Activities procuring open market items must follow FAR 8.402(f).

For administrative convenience, an ordering activity contracting officer may add items not on the Federal Supply Multiple Award Schedule (MAS) -- referred to as open market items -- to a Federal Supply Schedule blanket purchase agreement (BPA) or an individual task or delivery order, **only if-**

- (1) All applicable acquisition regulations pertaining to the purchase of the items not on the Federal Supply Schedule have been followed (e.g., publicizing (Part 5), competition requirements (Part 6), acquisition of commercial items (Part 12), contracting methods (Parts 13, 14, and 15), and small business programs (Part 19));
- (2) The ordering activity contracting officer has determined the price for the items not on the Federal Supply Schedule is fair and reasonable;
- (3) The items are clearly labeled on the order as items not on the Federal Supply Schedule; and
- (4) All clauses applicable to items not on the Federal Supply Schedule are included in the order.

18. CONTRACTOR COMMITMENTS, WARRANTIES AND REPRESENTATIONS

a. For the purpose of this contract, commitments, warranties and representations include, in addition to those agreed to for the entire schedule contract:

- (1) Time of delivery/installation quotations for individual orders;
 - (2) Technical representations and/or warranties of products concerning performance, total system performance and/or configuration, physical, design and/or functional characteristics and capabilities of a product/equipment/ service/software package submitted in response to requirements which result in orders under this schedule contract.
 - (3) Any representations and/or warranties concerning the products made in any literature, description, drawings and/or specifications furnished by the Contractor.
- b. The above is not intended to encompass items not currently covered by the GSA Schedule contract.

19. OVERSEAS ACTIVITIES

The terms and conditions of this contract shall apply to all orders for installation, maintenance and repair of equipment in areas listed in the pricelist outside the 48 contiguous states and the District of Columbia, except as indicated below:

Not Applicable.

Upon request of the Contractor, the ordering activity may provide the Contractor with logistics support, as available, in accordance with all applicable ordering activity regulations. Such ordering activity support will be provided on a reimbursable basis, and will only be provided to the Contractor's technical personnel whose services are exclusively required for the fulfillment of the terms and conditions of this contract.

20. BLANKET PURCHASE AGREEMENTS (BPAs)

The use of BPAs under any schedule contract to fill repetitive needs for supplies or services is allowable. BPAs may be established with one or more schedule contractors. The number of BPAs to be established is within the discretion of the ordering activity establishing the BPA and should be based on a strategy that is expected to maximize the effectiveness of the BPA(s). Ordering activities shall follow FAR 8.405-3 when creating and implementing BPA(s).

21. CONTRACTOR TEAM ARRANGEMENTS

Contractors participating in contractor team arrangements must abide by all terms and conditions of their respective contracts. This includes compliance with Clauses 552.238-74, Industrial Funding Fee and Sales Reporting, i.e., each contractor (team member) must report sales and remit the IFF for all products and services provided under its individual contract.

22. INSTALLATION, DEINSTALLATION, REINSTALLATION

The Davis-Bacon Act (40 U.S.C. 276a-276a-7) provides that contracts in excess of \$2,000 to which the United States or the District of Columbia is a party for construction, alteration, or repair (including painting and decorating) of public buildings or public works with the United States, shall contain a clause that no laborer or mechanic employed directly upon the site of the work shall received less than the prevailing wage rates as determined by the Secretary of Labor. The requirements of the Davis-Bacon Act do not apply if the construction work is incidental to the furnishing of supplies, equipment, or services. For example, the requirements do not apply to simple installation or alteration of a public building or public work that is incidental to furnishing supplies or equipment under a supply contract. However, if the construction, alteration or repair is segregable and exceeds \$2,000, then the requirements of the Davis-Bacon Act applies.

The ordering activity issuing the task order against this contract will be responsible for proper administration and enforcement of the Federal labor standards covered by the Davis-Bacon Act. The proper Davis-Bacon wage determination will be issued by the ordering activity at the time a request for quotations is made for applicable construction classified installation, deinstallation, and reinstallation services under SIN 132-8 or 132-9.

23. SECTION 508 COMPLIANCE.

If applicable, Section 508 compliance information on the supplies and services in this contract are available in Electronic and Information Technology (EIT) at the following: Not applicable. The EIT standard can be found at: www.Section508.gov/.

24. PRIME CONTRACTOR ORDERING FROM FEDERAL SUPPLY SCHEDULES.

Prime Contractors (on cost reimbursement contracts) placing orders under Federal Supply Schedules, on behalf of an ordering activity, shall follow the terms of the applicable schedule and authorization and include with each order –

- (a) A copy of the authorization from the ordering activity with whom the contractor has the prime contract (unless a copy was previously furnished to the Federal Supply Schedule contractor); and
- (b) The following statement:
This order is placed under written authorization from _____ dated _____. In the event of any inconsistency between the terms and conditions of this order and those of your Federal Supply Schedule contract, the latter will govern.

25. INSURANCE—WORK ON A GOVERNMENT INSTALLATION (JAN 1997)(FAR 52.228-5)

- (a) The Contractor shall, at its own expense, provide and maintain during the entire performance of this contract, at least the kinds and minimum amounts of insurance required in the Schedule or elsewhere in the contract.
- (b) Before commencing work under this contract, the Contractor shall notify the Contracting Officer in writing that the required insurance has been obtained. The policies evidencing required insurance shall contain an endorsement to the effect that any cancellation or any material change adversely affecting the Government's interest shall not be effective—
 - (1) For such period as the laws of the State in which this contract is to be performed prescribe; or
 - (2) Until 30 days after the insurer or the Contractor gives written notice to the Contracting Officer, whichever period is longer.
- (c) The Contractor shall insert the substance of this clause, including this paragraph (c), in subcontracts under this contract that require work on a Government installation and shall require subcontractors to provide and maintain the insurance required in the Schedule or elsewhere in the contract. The Contractor shall maintain a copy of all subcontractors' proofs of required insurance, and shall make copies available to the Contracting Officer upon request.

26. SOFTWARE INTEROPERABILITY.

Offerors are encouraged to identify within their software items any component interfaces that support open standard interoperability. An item's interface may be identified as interoperable on the basis of participation in a Government agency-sponsored program or in an independent organization program. Interfaces may be identified by reference to an interface registered in the component registry located at <http://www.core.gov>.

27. ADVANCE PAYMENTS

A payment under this contract to provide a service or deliver an article for the United States Government may not be more than the value of the service already provided or the article already delivered. Advance or pre-payment is not authorized or allowed under this contract. (31 U.S.C. 3324)

**TERMS AND CONDITIONS APPLICABLE TO INFORMATION TECHNOLOGY (IT)
PROFESSIONAL SERVICES (SPECIAL ITEM NUMBER 132-51)**

*****NOTE: All non-professional labor categories must be incidental to, and used solely to support professional services, and cannot be purchased separately.*

1. SCOPE

- a. The prices, terms and conditions stated under Special Item Number 132-51 Information Technology Professional Services apply exclusively to IT Professional Services within the scope of this Information Technology Schedule.
- b. The Contractor shall provide services at the Contractor's facility and/or at the ordering activity location, as agreed to by the Contractor and the ordering activity.

2. PERFORMANCE INCENTIVES I-FSS-60 Performance Incentives (April 2000)

- a. Performance incentives may be agreed upon between the Contractor and the ordering activity on individual fixed price orders or Blanket Purchase Agreements under this contract.
- b. The ordering activity must establish a maximum performance incentive price for these services and/or total solutions on individual orders or Blanket Purchase Agreements.
- c. Incentives should be designed to relate results achieved by the contractor to specified targets. To the maximum extent practicable, ordering activities shall consider establishing incentives where performance is critical to the ordering activity's mission and incentives are likely to motivate the contractor. Incentives shall be based on objectively measurable tasks.

3. ORDER

- a. Agencies may use written orders, EDI orders, blanket purchase agreements, individual purchase orders, or task orders for ordering services under this contract. Blanket Purchase Agreements shall not extend beyond the end of the contract period; all services and delivery shall be made and the contract terms and conditions shall continue in effect until the completion of the order. Orders for tasks which extend beyond the fiscal year for which funds are available shall include FAR 52.232-19 (Deviation – May 2003) Availability of Funds for the Next Fiscal Year. The purchase order shall specify the availability of funds and the period for which funds are available.
- b. All task orders are subject to the terms and conditions of the contract. In the event of conflict between a task order and the contract, the contract will take precedence.

4. PERFORMANCE OF SERVICES

- a. The Contractor shall commence performance of services on the date agreed to by the Contractor and the ordering activity.
- b. The Contractor agrees to render services only during normal working hours, unless otherwise agreed to by the Contractor and the ordering activity.

- c. The ordering activity should include the criteria for satisfactory completion for each task in the Statement of Work or Delivery Order. Services shall be completed in a good and workmanlike manner.
- d. Any Contractor travel required in the performance of IT Services must comply with the Federal Travel Regulation or Joint Travel Regulations, as applicable, in effect on the date(s) the travel is performed. Established Federal Government per diem rates will apply to all Contractor travel. Contractors cannot use GSA city pair contracts.

5. STOP-WORK ORDER (FAR 52.242-15) (AUG 1989)

- (a) The Contracting Officer may, at any time, by written order to the Contractor, require the Contractor to stop all, or any part, of the work called for by this contract for a period of 90 days after the order is delivered to the Contractor, and for any further period to which the parties may agree. The order shall be specifically identified as a stop-work order issued under this clause. Upon receipt of the order, the Contractor shall immediately comply with its terms and take all reasonable steps to minimize the incurrence of costs allocable to the work covered by the order during the period of work stoppage. Within a period of 90 days after a stop-work is delivered to the Contractor, or within any extension of that period to which the parties shall have agreed, the Contracting Officer shall either-
- (1) Cancel the stop-work order; or
 - (2) Terminate the work covered by the order as provided in the Default, or the Termination for Convenience of the Government, clause of this contract.
- (b) If a stop-work order issued under this clause is canceled or the period of the order or any extension thereof expires, the Contractor shall resume work. The Contracting Officer shall make an equitable adjustment in the delivery schedule or contract price, or both, and the contract shall be modified, in writing, accordingly, if-
- (1) The stop-work order results in an increase in the time required for, or in the Contractor's cost properly allocable to, the performance of any part of this contract; and
 - (2) The Contractor asserts its right to the adjustment within 30 days after the end of the period of work stoppage; provided, that, if the Contracting Officer decides the facts justify the action, the Contracting Officer may receive and act upon the claim submitted at any time before final payment under this contract.
- (c) If a stop-work order is not canceled and the work covered by the order is terminated for the convenience of the Government, the Contracting Officer shall allow reasonable costs resulting from the stop-work order in arriving at the termination settlement.
- (d) If a stop-work order is not canceled and the work covered by the order is terminated for default, the Contracting Officer shall allow, by equitable adjustment or otherwise, reasonable costs resulting from the stop-work order.

6. INSPECTION OF SERVICES

In accordance with FAR 52.212-4 CONTRACT TERMS AND CONDITIONS--COMMERCIAL ITEMS (MAR 2009) (DEVIATION I - FEB 2007) for Firm-Fixed Price orders and FAR 52.212-4 CONTRACT TERMS AND CONDITIONS -COMMERCIAL ITEMS (MAR 2009) (ALTERNATE I - OCT 2008) (DEVIATION I - FEB 2007) applies to Time-and-Materials and Labor-Hour Contracts orders placed under this contract.

7. RESPONSIBILITIES OF THE CONTRACTOR

The Contractor shall comply with all laws, ordinances, and regulations (Federal, State, City, or otherwise) covering work of this character. If the end product of a task order is software, then FAR 52.227-14 (Dec 2007) Rights in Data – General, may apply.

8. RESPONSIBILITIES OF THE ORDERING ACTIVITY

Subject to security regulations, the ordering activity shall permit Contractor access to all facilities necessary to perform the requisite IT Professional Services.

9. INDEPENDENT CONTRACTOR

All IT Professional Services performed by the Contractor under the terms of this contract shall be as an independent Contractor, and not as an agent or employee of the ordering activity.

10. ORGANIZATIONAL CONFLICTS OF INTEREST

a. Definitions.

“Contractor” means the person, firm, unincorporated association, joint venture, partnership, or corporation that is a party to this contract.

“Contractor and its affiliates” and “Contractor or its affiliates” refers to the Contractor, its chief executives, directors, officers, subsidiaries, affiliates, subcontractors at any tier, and consultants and any joint venture involving the Contractor, any entity into or with which the Contractor subsequently merges or affiliates, or any other successor or assignee of the Contractor.

An “Organizational conflict of interest” exists when the nature of the work to be performed under a proposed ordering activity contract, without some restriction on ordering activities by the Contractor and its affiliates, may either (i) result in an unfair competitive advantage to the Contractor or its affiliates or (ii) impair the Contractor’s or its affiliates’ objectivity in performing contract work.

b. To avoid an organizational or financial conflict of interest and to avoid prejudicing the best interests of the ordering activity, ordering activities may place restrictions on the Contractors, its affiliates, chief executives, directors, subsidiaries and subcontractors at any tier when placing orders against schedule contracts. Such restrictions shall be consistent with FAR 9.505 and shall be designed to avoid, neutralize, or mitigate organizational conflicts of interest that might otherwise exist in situations related to individual orders placed against the schedule contract. Examples of situations, which may require restrictions, are provided at FAR 9.508.

11. INVOICES

The Contractor, upon completion of the work ordered, shall submit invoices for IT Professional services. Progress payments may be authorized by the ordering activity on individual orders if appropriate. Progress payments shall be based upon completion of defined milestones or interim products. Invoices shall be submitted monthly for recurring services performed during the preceding month.

12. PAYMENTS

For firm-fixed price orders the ordering activity shall pay the Contractor, upon submission of proper invoices or vouchers, the prices stipulated in this contract for service rendered and accepted. Progress payments shall be made only when authorized by the order. For time-and-materials orders, the Payments under Time-and-Materials and Labor-Hour Contracts at FAR 52.212-4 (MAR 2009) (ALTERNATE I – OCT 2008) (DEVIATION I – FEB 2007) applies to time-and-materials orders placed under this contract. For labor-hour orders, the Payment under Time-and-Materials and Labor-Hour Contracts at FAR 52.212-4 (MAR 2009) (ALTERNATE I – OCT 2008) (DEVIATION I – FEB 2007) applies to labor-hour orders placed under this contract. 52.216-31(Feb 2007) Time-and-Materials/Labor-Hour Proposal Requirements—Commercial Item Acquisition As prescribed in 16.601(e)(3), insert the following provision:

- (a) The Government contemplates award of a Time-and-Materials or Labor-Hour type of contract resulting from this solicitation.
- (b) The offeror must specify fixed hourly rates in its offer that include wages, overhead, general and administrative expenses, and profit. The offeror must specify whether the fixed hourly rate for each labor category applies to labor performed by—
 - (1) The offeror;
 - (2) Subcontractors; and/or
 - (3) Divisions, subsidiaries, or affiliates of the offeror under a common control.

13. RESUMES

Resumes shall be provided to the GSA Contracting Officer or the user ordering activity upon request.

14. INCIDENTAL SUPPORT COSTS

Incidental support costs are available outside the scope of this contract. The costs will be negotiated separately with the ordering activity in accordance with the guidelines set forth in the FAR.

15. APPROVAL OF SUBCONTRACTS

The ordering activity may require that the Contractor receive, from the ordering activity's Contracting Officer, written consent before placing any subcontract for furnishing any of the work called for in a task order.

16. DESCRIPTION OF IT PROFESSIONAL SERVICES AND PRICING

- a. The Contractor shall provide a description of each type of IT Service offered under Special Item Numbers 132-51 IT Professional Services should be presented in the same manner as the Contractor sells to its commercial and other ordering activity customers. If the Contractor is proposing hourly rates, a description of all corresponding commercial job titles (labor categories) for those individuals who will perform the service should be provided.
- b. Pricing for all IT Professional Services shall be in accordance with the Contractor's customary commercial practices; e.g., hourly rates, monthly rates, term rates, and/or fixed prices, minimum general experience and minimum education.

LABOR CATEGORIES & DESCRIPTIONS

Commercial Job Title: Senior Software Developer

Minimum/General Experience: 5 plus years of software development. Ability to use programming languages such as C#, VB.NET, VB6, .NET 3.5 to code high complexity programs using top-down programming design logic. Ability to use relational databases to design and navigate complex database systems and have extensive knowledge with SQL. Working knowledge of Adobe Photoshop CS, UltraEdit-32, HTML Help Workstation, C1 Studio Enterprise, Dreamweaver, CGM, SVG, and LINQ.

Functional Responsibility: Responsible for researching, designing, writing and testing software programs in support of digitized schematics technology. The Senior Software Developer's duties include Software development using C# 2008 and Microsoft Access, Object-oriented Design and Analysis (OOA and OOD), front end graphical user interface design, software testing and quality assurance, performance tuning, improvement, balancing, usability, automation, integrating software with existing systems. evaluating and identifying new technologies for implementation, and working with Program Managers to determine program-specific software requirements.

Minimum Education: Accredited bachelor's degree in Computer Science, Management Information Systems or related field. Five (5) plus years of software development

Commercial Job Title: Multimedia Developer

Minimum/General Experience: 3 Plus years of multimedia development. Experience in creation of rich media with proficiency in using multimedia authoring tools such as Authorware, Flash (with Action Script) or similar software. Must have an artist's or designer's eye. Basic knowledge of logic expressions. Strong computer skills.

Functional Responsibility: Responsible for developing interactive schematics in support of digitized schematics technology under the guidance of senior engineers. The multimedia developer draws discrete circuits using Authorware, animates discrete circuits using Authorware, creates Locator Graphics using Paint Shop Pro and Authorware, follows appropriate procedures to ensure work is delivered to a quality defined by the customer and keeps job progress and time tracking sheets current.

Minimum Education: 1 year college, 3 Plus years in multimedia development

Commercial Job Title: Multimedia Developer - Entry Level

Minimum/General Experience: Interest in multimedia development. Experience in using multimedia authoring tools such as Authorware, Flash (with Action Script) or similar software. Must have an artist's or designer's eye. Basic knowledge of logic expressions. Strong computer skills.

Functional Responsibility: Responsible for developing interactive schematics in support of digitized schematics technology under the guidance of senior engineers. The multimedia developer draws discrete circuits using Authorware, animates discrete circuits using Authorware, creates Locator Graphics using Paint Shop Pro and Authorware, follows appropriate procedures to ensure work is delivered to a quality defined by the customer and keeps job progress and time tracking sheets current.

Minimum Education: High School Diploma, Some experience in using multimedia development tools

Commercial Job Title: Trace Processor

Minimum/General Experience: Prior experience with CAD software, CGM graphics editors or similar software (either on the job or educational). Basic knowledge of regular expressions. Familiarity with electrical schematics and ability to differentiate power and ground sources.

Functional Responsibility: Responsible for processing/digitizing schematics in support of digitized schematic technology. The Trace Processor uses various CAD programs to convert legacy documents into a functional, accurate, electronic interactive format, reviews and cleans-up of schematics using graphics software, resizes schematics using graphics software, hot-spots components and wires manually or using semi-automated tools, and follows appropriate procedures to ensure work is delivered to a quality defined by the customer.

Minimum Education: Two years college, Experience with CAD software, CGM graphics editors or similar software

Government Pricelist

|  DIGITIZED SCHEMATIC SOLUTIONS | | |
|-----------------------------------------------------------------------------------------------------------------|------------------------------------|-----------|
| SIN | LABOR CATEGORY | GSA PRICE |
| 132-51 | Senior Software Developer | \$156.17 |
| 132-51 | Multimedia Developer | \$112.00 |
| 132-51 | Multimedia Developer – Entry Level | \$70.53 |
| 132-51 | Trace Processor | \$156.17 |
| 132-51 | Senior Engineer | \$155.00 |
| 132-51 | Program Manager | \$213.00 |

**USA COMMITMENT TO PROMOTE
SMALL BUSINESS PARTICIPATION
PROCUREMENT PROGRAMS**

PREAMBLE

Digitized Schematic Solutions (DSS) LLC provides commercial products and services to ordering activities. We are committed to promoting participation of small, small disadvantaged and women-owned small businesses in our contracts. We pledge to provide opportunities to the small business community through reselling opportunities, mentor-protégé programs, joint ventures, teaming arrangements, and subcontracting.

COMMITMENT

To actively seek and partner with small businesses.

To identify, qualify, mentor and develop small, small disadvantaged and women-owned small businesses by purchasing from these businesses whenever practical.

To develop and promote company policy initiatives that demonstrate our support for awarding contracts and subcontracts to small business concerns.

To undertake significant efforts to determine the potential of small, small disadvantaged and women-owned small business to supply products and services to our company.

To insure procurement opportunities are designed to permit the maximum possible participation of small, small disadvantaged, and women-owned small businesses.

To attend business opportunity workshops, minority business enterprise seminars, trade fairs, procurement conferences, etc., to identify and increase small businesses with whom to partner.

To publicize in our marketing publications our interest in meeting small businesses that may be interested in subcontracting opportunities.

We signify our commitment to work in partnership with small, small disadvantaged and women-owned small businesses to promote and increase their participation in ordering activity contracts. To accelerate potential opportunities please contact

Margie Brunsell
Vice President / General Manager
Ph. (818) 889-1136 x101
Fax (818) 889-1476
E-mail: mbrunsell@digitizedschematic.com

**BEST VALUE
BLANKET PURCHASE AGREEMENT
FEDERAL SUPPLY SCHEDULE**

(Insert Customer Name)

In the spirit of the Federal Acquisition Streamlining Act (ordering activity) and (Contractor) enter into a cooperative agreement to further reduce the administrative costs of acquiring commercial items from the General Services Administration (GSA) Federal Supply Schedule Contract(s) _____.

Federal Supply Schedule contract BPAs eliminate contracting and open market costs such as: search for sources; the development of technical documents, solicitations and the evaluation of offers. Teaming Arrangements are permitted with Federal Supply Schedule Contractors in accordance with Federal Acquisition Regulation (FAR) 9.6.

This BPA will further decrease costs, reduce paperwork, and save time by eliminating the need for repetitive, individual purchases from the schedule contract. The end result is to create a purchasing mechanism for the ordering activity that works better and costs less.

Signatures

| | | | | | |
|-------------------|--|------|--|------------|------|
| Ordering Activity | | Date | | Contractor | Date |
|-------------------|--|------|--|------------|------|

BPA NUMBER _____

**(CUSTOMER NAME)
BLANKET PURCHASE AGREEMENT**

Pursuant to GSA Federal Supply Schedule Contract Number(s) _____, Blanket Purchase Agreements, the Contractor agrees to the following terms of a Blanket Purchase Agreement (BPA) EXCLUSIVELY WITH (ordering activity):

(1) The following contract items can be ordered under this BPA. All orders placed against this BPA are subject to the terms and conditions of the contract, except as noted below:

| MODEL NUMBER/PART NUMBER | *SPECIAL BPA DISCOUNT/PRICE |
|--------------------------|-----------------------------|
| _____ | _____ |
| _____ | _____ |
| _____ | _____ |

(2) Delivery:

| DESTINATION | DELIVERY SCHEDULES / DATES |
|-------------|----------------------------|
| _____ | _____ |
| _____ | _____ |
| _____ | _____ |

(3) The ordering activity estimates, but does not guarantee, that the volume of purchases through this agreement will be _____.

(4) This BPA does not obligate any funds.

(5) This BPA expires on _____ or at the end of the contract period, whichever is earlier.

(6) The following office(s) is hereby authorized to place orders under this BPA:

| OFFICE | POINT OF CONTACT |
|--------|------------------|
| _____ | _____ |
| _____ | _____ |
| _____ | _____ |

(7) Orders will be placed against this BPA via Electronic Data Interchange (EDI), FAX, or paper.

(8) Unless otherwise agreed to, all deliveries under this BPA must be accompanied by delivery tickets or sales slips that must contain the following information as a minimum:

- (a) Name of Contractor;
- (b) Contract Number;
- (c) BPA Number;
- (d) Model Number or National Stock Number (NSN);
- (e) Purchase Order Number;
- (f) Date of Purchase;
- (g) Quantity, Unit Price, and Extension of Each Item (unit prices and extensions need not be shown when incompatible with the use of automated systems; provided, that the invoice is itemized to show the information); and
- (h) Date of Shipment.

(9) The requirements of a proper invoice are specified in the Federal Supply Schedule contract. Invoices will be submitted to the address specified within the purchase order transmission issued against this BPA.

(10) The terms and conditions included in this BPA apply to all purchases made pursuant to it. In the event of an inconsistency between the provisions of this BPA and the Contractor's invoice, the provisions of this BPA will take precedence.

BASIC GUIDELINES FOR USING “CONTRACTOR TEAM ARRANGEMENTS”

Federal Supply Schedule Contractors may use “Contractor Team Arrangements” (see FAR 9.6) to provide solutions when responding to a ordering activity requirements.

These Team Arrangements can be included under a Blanket Purchase Agreement (BPA). BPAs are permitted under all Federal Supply Schedule contracts.

Orders under a Team Arrangement are subject to terms and conditions or the Federal Supply Schedule Contract.

Participation in a Team Arrangement is limited to Federal Supply Schedule Contractors.

Customers should refer to FAR 9.6 for specific details on Team Arrangements.

Here is a general outline on how it works:

- The customer identifies their requirements.
- Federal Supply Schedule Contractors may individually meet the customers needs, or -
- Federal Supply Schedule Contractors may individually submit a Schedules “Team Solution” to meet the customer’s requirement.
- Customers make a best value selection.