

**TABLE OF CONTENTS**

**Important GSA Contract Information ..... page 2**

**TIME Manufacturing – Versalift Distributors ..... page 5**

**How to Use This Catalog..... page 15**

**Base Model Prices ..... page 16**

**Product Description and Price List**

TEL-29-N .....page 17  
TEL-29-NE .....page 19  
TEL-29-IH .....page 21  
TEL-29-EIH .....page 22  
VANTEL-29-N .....page 23  
VANTEL-29-IH .....page 27  
ET-32-NF .....page 29  
T-3100-N .....page 31  
T-3100-I .....page 33  
LT-56-NE .....page 35  
LT-62-NE .....page 37  
SST-37-ENH .....page 39  
SST-37-EIH .....page 41  
SST-40-EIH .....page 43  
VST-36-N .....page 45  
VST-36-I .....page 47  
VST-40-N .....page 49  
VST-40-I .....page 51  
VST-5000-I .....page 53  
VST-5500-I .....page 55  
VST-6000-I .....page 57  
VN-55-I .....page 59  
VO-36-I .....page 61  
VO-40-MHI .....page 63  
VO-43-I .....page 65  
VO-255-I .....page 67  
VO-255-I (Chipper/Forestry) .....page 69  
VO-260-I (Chipper/Forestry) .....page 71  
VO-350-MHI .....page 73  
VO-355-MHI .....page 75

## GSA Catalog & Price List

### **Important GSA Contract Information**

FSC GROUP: 23 Part V

CLASS(ES): 3825, 3950

CONTRACT NUMBER: GS-30F-1024H

CONTRACT PERIOD: 7/30/2007 through 7/31/2012

CONTRACTOR: TIME Manufacturing Co.  
P.O. Box 20368  
Waco, Texas 76702-0368  
Phone: 254-399-2100  
[www.versalift.com](http://www.versalift.com)

CONTACTS: Jack Jeffrey  
National Sales Manager  
Phone: 254-399-2198  
Fax: 877-329-7278  
Cell: 254-744-3954  
Email: [jackj@timemfg.com](mailto:jackj@timemfg.com)

Stan Tomchesson  
GSA Contract Coordinator  
Phone: 254-399-2167  
Fax: 254-399-2651  
E-mail: [stant@timemfg.com](mailto:stant@timemfg.com)

Amber Scott  
Marketing Manager  
Phone: 254-399-2605  
Fax: 877-329-7278  
E-mail: [ambers@timemfg.com](mailto:ambers@timemfg.com)

BUSINESS SIZE: Small

SPECIAL ITEM NUMBERS .....232-1, Vehicle Mounted Personnel Lifts

LOWEST PRICED MODEL ..... 232-1, Vantel-29-N, \$47,167.00

MAXIMUM ORDER ..... 25 UNITS

MINIMUM ORDER..... \$100.00

GEOGRAPHIC COVERAGE ..... 48 CONTIGUOUS STATES

POINT(S) OF PRODUCTION ..... Waco, Texas; McLennan County and:  
See list of Distributors on pages 5-18

DISCOUNT .....Prices shown are NET

QUANTITY DISCOUNT .....2-4 .5%  
5-10 1%  
11-20 1.5%  
21+ 2.0%

PROMPT PAYMENT TERMS ..... 1% Ten (10) Days, Net 30 Days

GOVERNMENT PURCHASE CARD ..... Accepted below and above  
the micro-purchase threshold

FOREIGN ITEMS .....None

TIME OF DELIVERY ..... 180 Days, ARO

EXPEDITED DELIVERY ..... Contact Contractor

OVERNIGHT AND TWO-DAY DELIVERY ..... Not Available

URGENT REQUIREMENTS..... Contact Contractor

FOB POINT ..... Destination

## GSA Catalog & Price List

ORDERING ADDRESS .....	TIME Manufacturing Co. P.O. Box 20368 Waco, Texas 76702-0368
ORDERING PROCESS .....	For Supplies and Services, the ordering Procedures, information on Blanket Purchase Agreements (BPAs) and a sample BPA can be found at the GSA/FSS Schedule Homepage on the internet at <a href="http://fss.gsa.gov/schedules">fss.gsa.gov/schedules</a> .
PAYMENT ADDRESS .....	TIME Manufacturing Co. P.O. Box 20368 Waco, Texas 76702-0368
BY WIRE TRANSFER .....	Texas First Bank P.O. Box 2524 Waco, Texas 76706-2524 Routing No: 111908949 Account No: 21002852
WARRANTY .....	One Year Parts and Labor
SERVICE AND DISTRIBUTION POINTS .....	See pages 5-15
PREVENTATIVE MAINTENANCE.....	See Manual
DUNS NUMBER .....	00-750-3469

**TIME Manufacturing – Versalift Distributors**

**Western Division:**

<b>Ameri-Tech Equipment Company</b>	
970 Oildale Street Evansville, WY 82636	Phone: 307-234-9921 Toll-free: 800-303-9921 Fax: 307-234-3432
PO Box 2888 Casper, WY 82602-2888	Website: <a href="http://www.ateccasper.com">www.ateccasper.com</a>
<b>COVERAGE AREA</b>	
<b>State of Wyoming</b>	

<b>Drake-Scruggs Equipment, Inc. (MAIN)</b>	
2000 S. Dirksen Pkwy Springfield, IL 62703	Phone: 217-753-3871 Fax: 217-753-2760
PO Box 2549 Springfield, IL 62708	Website: <a href="http://www.drake-scruggs.com">www.drake-scruggs.com</a>
<b>Drake-Scruggs Equipment, Inc. (BRANCH)</b>	
4101 W. Main St. Grandview, MO 64030	Phone: 816-765-5525 Fax: 816-765-8522
PO Box 2888	Website: <a href="http://www.drake-scruggs.com">www.drake-scruggs.com</a>
<b>COVERAGE AREA</b>	
<b>State of Missouri</b>	
<b>State of Oklahoma</b>	
(Counties: Washington, Nowata, Craig, Ottawa, Rogers, Mayes, Delaware, Wagoner, Cherokee, and Adair)	
<b>State of Illinois</b>	
(All counties except: Boone, Cook, DeKalb, DuPage, Kane, Kendall, McHenry, Will)	
<b>State of Nebraska</b>	
(Counties: Adams, Antelope, Boone, Boyde, Brown, Burt, Butler, Cass, Dedar, Clay, Colfax, Cuming, Dakota, Deuel, Dixon, Dodge, Douglas, Fillmore, Gage, Garfield, Greeley, Hall, Hamilton, Holt, Howard, Jefferson, Johnson, Keya Paha, Knox, Lancaster, Madison, Merrick, Nance, Nemaha, Nuckolls, Otoe, Pawnee, Pierce, Platte, Polk, Richardson, Rock, Saline, Sarpy, Saunders, Seward, Stanton, Thayer, Thurston, Washington, Wayne, Webster, Wheeler, York)	
<b>State of Kansas</b>	
(Counties: Allen, Anderson, Atchison, Barber, Barton, Bourbon, Brown, Butler, Chautauqua, Cherokee, Chase, Clay, Cloud, Coffey, Comanche, Cowley, Crawford, Dickinson, Doniphan, Douglas, Edwards, Ellis, Elk, Ellsworth, Franklin, Geary, Greenwood, Harper, Harvey, Jackson, Jefferson, Jewell, Johnson, Kingman, Kiowa, Labette, Leavenworth, Lincoln, Linn, Lyon, Marion, Marshall, McPherson, Miami, Mitchell, Montgomery, Morris, Nemaha, Neosho, Osage, Osborne, Ottawa, Pawnee, Phillips, Pottawatomie, Pratt, Reno, Republic, Rice, Riley, Rooks, Rush, Russell, Saline, Sedgwick, Shawnee, Smith, Stafford, Sumner, Wabaunsee, Washington, Wilson, Woodson, Wyandotte)	

**Western Division (con't):**

<b>Layton Truck Equipment Co., LLC (MAIN)</b>	
2425 E. Platte Place Colorado Springs, CO 80909	Phone: 719-597-0400 Fax: 719-597-2122  Website: <a href="http://www.laytontruck.com">www.laytontruck.com</a>
<b>Layton Truck Equipment Co., LLC (BRANCH)</b>	
11951 East 33rd Ave. Aurora, CO 80010	Phone: 303-365-8828 Fax: 303-365-8814  Website: <a href="http://www.laytontruck.com">www.laytontruck.com</a>
<b>COVERAGE AREA</b>	
<b>State of Colorado</b>	
<b>State of Kansas</b>	
(Counties: Cheyenne, Clark, Decatur, Finney, Ford, Gove, Graham, Grant, Gray, Greeley, Haskell, Hodgeman, Kearny, Lane, Logan, Meade, Morton, Ness, Norton, Rawlins, Scott, Seward, Sheridan, Sherman, Stanton, Stevens, Thomas, Trego, Wallace)	
<b>State of Nebraska</b>	
(Counties: Arthur, Banner, Blaine, Box Butte, Buffalo, Chase, Cherry, Cheyenne, Custer, Dawes, Dawson, Dundy, Franklin, Frontier, Furnas, Garden, Gosper, Grant, Harlan, Hayes, Hitchcock, Hooker, Kearney, Keith, Kimball, Lincoln, Logan, Loup, McPherson, Morrill, Perkins, Phelps, Red Willow, Scotts Bluff, Sheridan, Sherman, Sioux, Thomas, Valley)	

<b>Mountain States Industrial Services (MSIS)</b>	
1015 West 1700 South Salt Lake City, UT 84104	Phone: 801-972-1166 Fax: 801-972-6101  Website: <a href="http://www.msisutah.com">www.msisutah.com</a>
<b>COVERAGE AREA</b>	
<b>State of Utah</b>	

**Western Division (con't):**

<b>Nelson Truck Equipment</b>	
20063 84th Ave So. Kent, WA 98032	Phone: 253-395-3825 Toll-free: 800-877-0338 Fax: 253-872-6583  Website: www.nelsontruck.com
<b>Titan Truck Equipment</b>	
PO Box 13056 605 N. Francher Rd. Spokane, WA 99215	Phone: 509-755-5037 Fax: 509-755-5303  Website: www.titantruck.com
<b>COVERAGE AREA</b>	
<b>State of Montana</b>	
<b>State of Washington</b>	
<b>State of Idaho</b>	
(Counties north of the Salmon River: Benewah, Bonner, Boundary, Clearwater, Idaho, Kootenai, Latch, Lewis, Nez Perce, Shoshone)	
<b>State of Oregon</b>	
(ALL counties excluding: Baker, Grant, Harney, Malheur, Umatilla, Union, Wallowa)	

<b>Truck Hydraulic Equipment Company Inc.</b>	
14262 Whittram Ave. Fontana, CA 92335	Phone: 909-428-0280 Toll-free: 800-428-8010 Fax: 909-428-0948 Website: www.thecoinc.com
<b>COVERAGE AREA</b>	
<b>Southern California</b>	
(Counties: San Luis Obispo, Kern, Santa Barbara, Ventura, Los Angeles, San Bernardino, Orange, Riverside, Sand Diego, and Imperial.) <i>The Dealer also has the right to sell to CALTRANS, whose purchasing offices are located in Sacramento, California, realizing that equipment purchased can ultimately be located in both Southern and Northern California.</i>	

**Western Division (con't):**

<b>Utility Crane &amp; Equipment (MAIN)</b>	
2239 N. Black Canyon Hwy. Phoenix, AZ 85009	Phone: 602-393-4610 Toll-free: 866-832-4833 Fax: 602-393-4613  Website: <a href="http://www.utilityce.com">www.utilityce.com</a>
<b>New Mexico Branch</b>	
1901 Broadway NE Albuquerque, NM 87110	Phone: 602-999-5354 Toll-free: 866-832-431
<b>Trucks West of Nevada (Branch)</b>	
3038 Losee Road North Las Vegas, NV 89030	Phone: 702-649-4256 Toll-free: 800-879-7902 Fax: 702-649-7134
<b>COVERAGE AREA</b>	
State of Arizona State of New Mexico Clark County, Nevada El Paso County, Texas	

<b>Utility Trailer Sales of Idaho, Inc.</b>	
7350 Eisenman Rd. Boise, ID 83716  PO Box 15357 Boise, ID 83715	Phone: 208-336-0138 Toll-free: 800-627-3642 Fax: 208-336-8068  Website: <a href="http://www.utilityboise.com">www.utilityboise.com</a>
<b>COVERAGE AREA</b>	
<b>Idaho</b> (Portion of the state south of the Salmon River: Ada, Adams, Bannock, Bear Lake, Bingham, Blaine, Boise, Bonneville, Butte, Camas, Canyon, Caribou, Cassia, Clark, Custer, Elmore, Franklin, Fremont, Gem, Gooding, Jefferson, Jerome, Lemhi, Lincoln, Madison, Minidoka, Oneida, Owyhee, Payette, Power, Teton, Twin Falls, Valley, Washington) <b>Eastern Oregon</b> (Counties: Baker, Grant, Harney, Malheur, Umatilla, Union, Wallowa)	



Western Division (con't):

<b>Versalift Southwest</b>	
1200 Texas Central Pkwy Waco, TX 76712	Phone: 254-420-5330 Toll-free: 800-639-4005 Fax: 254-776-8025
PO Box 21415 Waco, TX 76712	
<b>COVERAGE AREA</b>	
<b>State of Texas (except El Paso County)</b>	
<b>State of Oklahoma</b>	
Except the following counties: Adair, Cherokee, Craig, Delaware, Mayes, Nowata, Ottawa, Rogers, Wagoner, Washington.	
<b>State of Louisiana</b>	
<b>State of Arkansas</b>	

**TIME Manufacturing – Versalift Distributors**

**Central Division:**

<b>ABM Equipment &amp; Supply, Inc.</b>	
333 Second Street, NE Hopkins, MN 55343	Phone: 952-938-5451 Toll-free: 800-229-5451 Fax: 952-938-0159
Website: <a href="http://www.abm-highway.com">www.abm-highway.com</a>	
<b>COVERAGE AREA</b>	
State of Iowa State of Minnesota State of North Dakota State of South Dakota	

<b>Aerial Truck Equipment Co.</b>	
8270 Craft Road Olive Branch, MS 38654	Phone: 662-895-8600 Fax: 662-895-7047
PO Box 716 Olive Branch, MS 38654	Website: <a href="http://www.aerialtruck.com">www.aerialtruck.com</a>
<b>COVERAGE AREA</b>	
State of Mississippi State of Tennessee	
(Counties west of the Tennessee River): Benton, Carroll, Chester, Crockett, Decatur, Dyer, Fayette, Gibson, Hardeman, Hardin, Haywood, Henderson, Henry, Lake, Lauderdale, Madison, McNairy, Obion, Shelby, Tipton, Weakly)	

<b>Cannon Engineering &amp; Equipment Co.</b>	
51761 Danview Technologies Ct. Shelby Township, MI 48315	Phone: 586-991-0054 Fax: 586-991-0074
Website: <a href="http://www.cannonequip.com">www.cannonequip.com</a>	
<b>COVERAGE AREA</b>	
State of Michigan	
(All counties except: Alger, Baraga, Chippewa, Delta, Dickinson, Gogebic, Houghton, Iron, Keweenaw, Luce, Mackinac, Marquette, Menominee, Ontonagon, Schoolcraft)	

**Central Division (con't):**

<b>MAP Enterprises, Inc.</b>	
610 Hanover Rd Graham, NC 27253	Phone: 336-228-1722 Fax:336-228-7205
PO Box 3097 Burlington, NC 27216-3097	Website: <a href="http://www.mapenterprises.com">www.mapenterprises.com</a>
<b>COVERAGE AREA</b>	
<b>State of North Carolina</b> <b>State of South Carolina</b> <b>State of Virginia</b>	
(all counties excluding: Accomack, Arlington, Clarke, Fairfax, Fauquier, Frederick, Loudoun, North Hampton, Prince William, Shenandoah, Stafford, Warren)	

<b>O.G. Hughes &amp; Sons, Inc.</b>	
4816 Rutledge Pike Knoxville, TN 37914	Phone: 865-524-7525 Toll-free: 800-949-8864 Fax: 865-637-1135
PO Box 6328 Knoxville, TN 37914	Website: <a href="http://www.oghughes.com">www.oghughes.com</a>
<b>O.G. Hughes &amp; Sons, Inc.</b>	
420 Fairmont Drive Norcross, GA 30071	
<b>COVERAGE AREA</b>	
<b>State of Georgia</b>	
(All Counties except: Baker, Brooks, Calhoun, Clay, Colquitt, Crisp, Decatur, Dougherty, Early, Echols, Grady, Lee, Mitchell, Quitman, Randolph, Seminole, Stewart, Sumter, Terrell, Thomas, Troup, Webster, Worth)	
<b>State of Tennessee</b>	
All counties east of the Tennessee River	
<b>State of Alabama</b>	
(Counties: Blount, Cherokee, Colbert, Cullman, DeKalb, Fayette, Franklin, Jackson, Lamar, Lauderdale, Lawrence, Limestone, Madison, Marion, Marshall, Morgan, Walker, Winston)	

<b>Power Equipment Leasing Company</b>	
605 Anderson Drive Romeoville, IL 60446-1687	Phone: 815-886-1776 Toll-free: 800-521-0246 Fax: 815-886-1161
Website: <a href="http://www.powerequipmentleasing.com">www.powerequipmentleasing.com</a>	
<b>COVERAGE AREA</b>	
<b>State of Illinois</b>	
(Counties: Boone, Cook, DeKalb, DuPage, Kendall, Kane, McHenry, Will)	

**Central Division (con't):**

**Stamm Manufacturing**

4850 Orange Avenue Phone: 772-461-6056  
Fort Pierce, FL 34947 Toll-free: 800-226-5056  
Fax: 772-464-2716  
Website: www.stamm-mfg.com

**COVERAGE AREA**

**State of Florida**

(Counties: Alachua, Baker, Bradford, Brevard, Broward, Clay, Duval, entire Florida Keys, Indian River, Martin, Miami-Dade, Nassau, Okeechobee, Osceola, Palm Beach, Putman, Seminole, St. Johns, St. Lucie, Union, Volusia)

**Truck Equipment Sales, Inc. (MAIN)**

4700 Rangeline Road Phone: 251-666-8606  
Mobile, AL 36619 Toll-free: 800-633-6946  
Fax: 251-666-8676  
Website: www.truckequipmentsales.com

**Truck Equipment Sales, Inc. (BRANCH)**

2625 Highway 29 South Phone: 850-438-7596  
Cantonment, FL 32533 Toll-free: 800-848-8527  
Fax: 850-438-7599  
Website: www.truckequipmentsales.com

**COVERAGE AREA**

**State of Florida**

(Counties: Escambia, Santa Rosa, Okaloosa, Walton, Holmes, Jackson, Graceville, Washington, Bay, Calhoun, Gulf, Gadsden, Liberty, Franklin, Leon, Wakulla, Jefferson, Madison, Taylor, Hamilton, Suwannee, Lafayette, Dixie, Columbia, Gilchrist)

**State of Georgia**

(Counties: Baker, Brooks, Calhoun, Clay, Colquitt, Crisp, Decatur, Dougherty, Early, Echols, Grady, Lee, Mitchell, Quitman, Randolph, Seminole, Stewart, Sumter, Terrell, Thomas, Troup, Webster, Worth)

**State of Alabama**

(All counties, except: Blount, Cherokee, Colbert, Cullman, DeKalb, Fayette, Franklin, Jackson, Lamar, Lauderdale, Lawrence, Limestone, Madison, Marion, Marshall, Morgan, Walker, Winston) *Excludes Alabama Power Company (a division of the Southern Company)*

**Central Division (con't):**

<b>Utility Sales &amp; Service, Inc. (USS)</b>	
412 Randolph Drive Appleton, WI 54913	Phone: 920-788-2699 Fax: 920-788-4699
PO Box 716 Olive Branch, MS 38654	Website: <a href="http://www.utilityssi.com">www.utilityssi.com</a>
<b>COVERAGE AREA</b>	
<b>State of Wisconsin State of Michigan</b>	
(Counties: Alger, Baraga, Chippewa, Delta, Dickinson, Gogebic, Houghton, Iron, Keheenasaw, Luse, Machinac, Marquette, Menohiee, Ontonagaon, Schoolcraft) (906 Area Code)	

<b>Utility Truck Equipment, Inc. (UTE)</b>	
23893 US 23 South Circleville, OH 43113	Phone: 740-474-5151 Fax: 740-474-4402 Parts Fax: 740-474-9488
PO Box 130 Circleville, OH 43113	Website: <a href="http://www.utilitytruck.net">www.utilitytruck.net</a>
<b>COVERAGE AREA</b>	
<b>State of Indiana State of Ohio State of Kentucky</b>	

<b>Utility Truck &amp; Equipment Service, Inc. (UT&amp;ES)</b>	
11679 North Hwy 301 Thonotosassa, FL 33592	Phone: 813-982-8282 Toll-free: 877-259-8800 Fax: 813-982-8283 Website: <a href="http://www.utilitytrks.com">www.utilitytrks.com</a>
<b>COVERAGE AREA</b>	
<b>State of Florida</b>	
(Counties: Charlotte, Citrus, Collier, Desoto, Glades, Hardee, Hendry, Hernando, Highlands, Hillsborough, Lake, Lee, Levy, Manatee, Marion, Monroe, Pasco, Pinellas, Polk, Sarasota, and Sumter.) <i>NOTE: This covers all customers and industries with the exception of all Sign, Lighting, and Signal customers. These customers will be handled exclusively by Stamm Manufacturing for the above listed counties in the state of Florida.</i>	

**TIME Manufacturing – Versalift Distributors**

**Eastern Division:**

<b>North American Equipment Upfitters - NAEU (MAIN)</b>	
Service Facility 6 Sutton Circle Hooksett, NH 03106	Phone:603-624-6288 Fax: 603-624-6289  Website: www.naeuinc.com
<b>North American Equipment Upfitters-NAEU (Branch)</b>	
Sales & Service 6708 Townline Road Syracuse, NY 13221	Phone: 315-455-5438 Fax: 315-455-5454  Website: www.naeuinc.com
<b>North American Equipment Upfitters-NAEU (Branch)</b>	
PO Box 246 3 Vauee Lane Old Orchard Beach, ME 04064	
<b>COVERAGE AREA</b>	
State of New York State of Connecticut State of Maine State of Massachusetts State of New Hampshire State of Rhode Island State of Vermont	

<b>Versalift East</b>	
2706 Brodhead Road Bethlehem, PA 18020-9411	Phone: 610-866-1400 Toll-free: 888-866-1400 Fax: 610-694-9792 Fax: 610-887-2990  Website: www.VersaliftEast.Com
<b>COVERAGE AREA</b>	
State of Delaware State of Maryland State of New Jersey State of Pennsylvania State of West Virginia State of Virginia  (Counties: Accomack, Arlington, Clark, Fairfax, Fauquier, Frederick, Loudoun, North Hampton, Prince William, Shenandoah, Stafford, Warren)	

## **How To Use This Catalog**

The GSA (General Services Administration) is a federal agency that handles more than one fourth of the U.S. government's total procurements. TIME Manufacturing Company's GSA contract means that we are an approved vendor and that we agree to supply certain specified products at predetermined prices. The contract is designed to benefit GSA buyers by allowing them to buy what they want, instead of being locked into buying low price as the result of a competitive bid process.

As a distributor, you can benefit from this contract in several ways. The most obvious being that you can sell to federal agencies without going through a competitive bid process. Perhaps more importantly, it also means that many other institutions, other than actual federal agencies, can also purchase through GSA, simply because they receive some sort of federal funding. Examples are prisons, airports, colleges, universities, and even cities. Finally, you can benefit from this contract because it gives you the option of doing profitable mounting at your location, or you can opt to have us do the mounting and simply collect an attractive fee for handling the order.

This contract makes it really easy to sell, and the single most important thing you need to remember is simply to ask prospective customers, "Can you buy through GSA?" If they can, use the included "Product Description and Price List" to help your customer identify the basic type of equipment they need. Having gotten that far, you will probably need to supply more detailed descriptions of either the lift, chassis, or body, and your customer may want something different from the standard package offered in the contract. In addition to the options offered as a part of our contract, you will also find that your GSA customers can get very "creative" on their own by issuing additional purchase orders to "add to" and "build" the unit they want.

In addition to these GSA catalogs, designed primarily as a sales tool, each distributor is supplied with a confidential Distributor Guide. This Guide supplies more details on a) exactly how these units are equipped, b) how we developed the pricing and c) how the distributor gets paid depending on whether or not they do the installation. Remember that GSA purchase orders are issued to TIME Manufacturing Company and not the distributor, so you do need to be aware of how the contract works. Should you need additional information, please contact Stan Tomchesson at 254-399-2167 or via email at [stant@timemfg.com](mailto:stant@timemfg.com).

## GSA Catalog & Price List

### **BASE MODEL PRICES**

TEL-29-N.....	\$53,367.00	.....	page 17
TEL-29-NE .....	\$54,817.00	.....	page 19
TEL-29-IH.....	\$58,973.00	.....	page 21
TEL-29-EIH .....	\$59,033.00	.....	page 23
VANTEL-29-N .....	\$47,167.00	.....	page 25
VANTEL-29-IH .....	\$51,444.00	.....	page 27
ET-32-NF .....	\$56,391.00	.....	page 29
T-3100-N.....	\$64,489.00	.....	page 31
T-3100-I.....	\$67,428.00	.....	page 33
LT-56-NE.....	\$97,439.00	.....	page 35
LT-62-NE.....	\$119,391.00	.....	page 37
SST-37-ENH .....	\$64,978.00	.....	page 39
SST-37-EIH.....	\$67,927.00	.....	page 41
SST-40-EIH.....	\$68,820.00	.....	page 43
VST-36-N .....	\$94,844.00	.....	page 45
VST-36-I.....	\$99,065.00	.....	page 47
VST-40-N .....	\$95,757.00	.....	page 49
VST-40-I.....	\$100,086.00	.....	page 51
VST-5000-I.....	\$133,991.00	.....	page 53
VST-5500-I.....	\$143,897.00	.....	page 55
VST-6000-I.....	\$148,447.00	.....	page 57
VN-55-I.....	\$120,343.00	.....	page 59
VO-36-I.....	\$88,106.00	.....	page 61
VO-40-MHI .....	\$84,966.00	.....	page 63
VO-43-I.....	\$96,219.00	.....	page 65
VO-255-I.....	\$126,576.00	.....	page 67
VO-255-I (Chipper/Forestry).....	\$128,745.00	.....	page 69
VO-260-I (Chipper/Forestry).....	\$129,884.00	.....	page 71
VO-350-MHI .....	\$150,770.00	.....	page 73
VO-355-MHI .....	\$152,169.00	.....	page 75



**TEL-29-N**

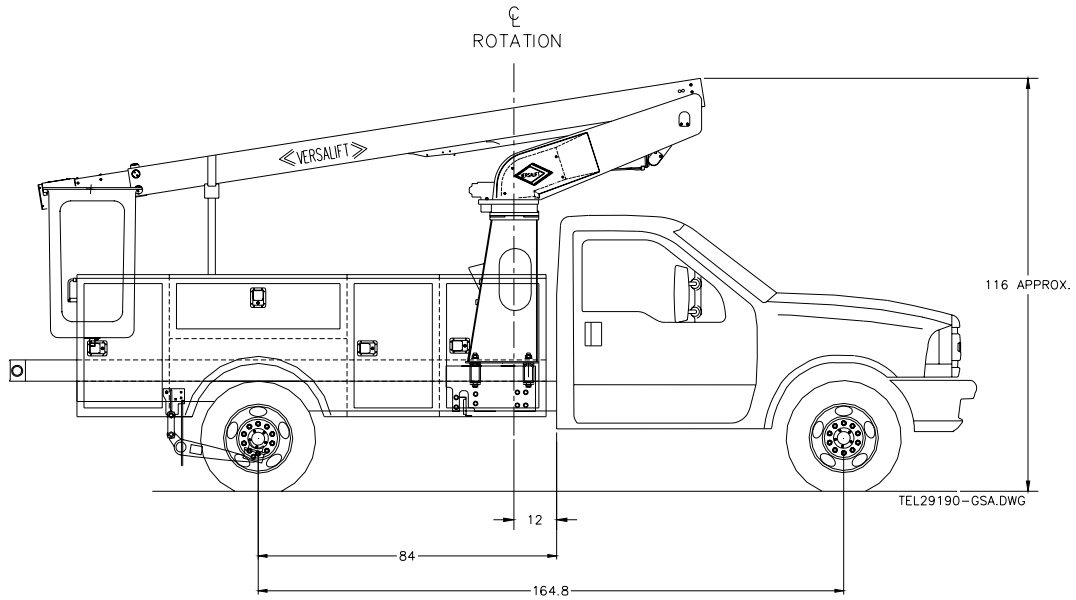

*Versalift Model No.*      **TEL-29-N**

*Description:*                      Non-insulated, side mounted 28 ft. 9 in. (8.76 m) telescopic aerial platform lift, including 350 lb. platform capacity.

*Chassis Model*                      **FORD F350 4X2**

*Description:*                      11,200 lb. GVWR cab and chassis with 84 inch cab to axle, six (6) speed manual transmission, 5.4L V8 gas engine, AM/FM radio, and no air conditioning.

*Body Model*                         **STEEL SERVICE BODY**

*Description:*                      132 inch steel service body with standard compartments, treadplate tops and floor, and 24 inch tailshelf.

*Installed Items*                    **INSTALLATION**

*Description:*                      Install Versalift Tel-29-N and service body on chassis. Installation also includes belt drive system, rear torsion bar, and painting body to match chassis.

<b>COMPLETE TOTAL PRICE F.O.B. DESTINATION:</b>	<b>\$ 53,367.00</b>
-------------------------------------------------	---------------------

**TEL-29-N STANDARD OPTIONS**

Continuous Rotation .....	\$1,815.00
Generator w/Cover .....	\$3,755.00
Splicer Platform .....	\$ 194.00
Tent, Top, Door, Seat, Pouch.....	\$1,048.00
Platform Leveling .....	\$1,195.00
Platform Tilt .....	\$ 374.00
24" x 30" Platform .....	\$ 178.00
Hydraulic Tool Power at Platform (Requires 2-speed throttle) .....	\$ 90.00
Hydraulic Tool Power at Rear (Requires 2-speed throttle) .....	\$ 360.00
One (1) Set of Outriggers in Lieu of Torsion Bars .....	\$2,160.00
Outrigger Boom Interlock .....	\$ 925.00
Two Speed Throttle .....	\$ 447.00
Variable Speed .....	\$ 677.00
Emergency Power .....	\$ 460.00
Air Conditioning-Ford .....	\$1,511.00
Central Locking .....	\$ 280.00
Chock Block Holders .....	\$ 160.00
Compartment Lighting .....	\$ 720.00
Flood Light .....	\$ 616.00
Strobe .....	\$ 418.00
Back Up Alarm .....	\$ 197.00
Pintle & Plug .....	\$ 730.00
Unitrol Single Stick .....	\$ 430.00
Priority Flow Control .....	\$ 530.00
Automatic Transmission-Ford, Gas .....	\$1,195.00
Dimensions 1800W Inverter w/Battery and Cover .....	\$2,454.00

**COLOR BROCHURES AVAILABLE UPON REQUEST  
OR VISIT TIME ON THE WEB AT:  
[WWW.VERSALIFT.COM](http://WWW.VERSALIFT.COM)**

### TEL-29-NE

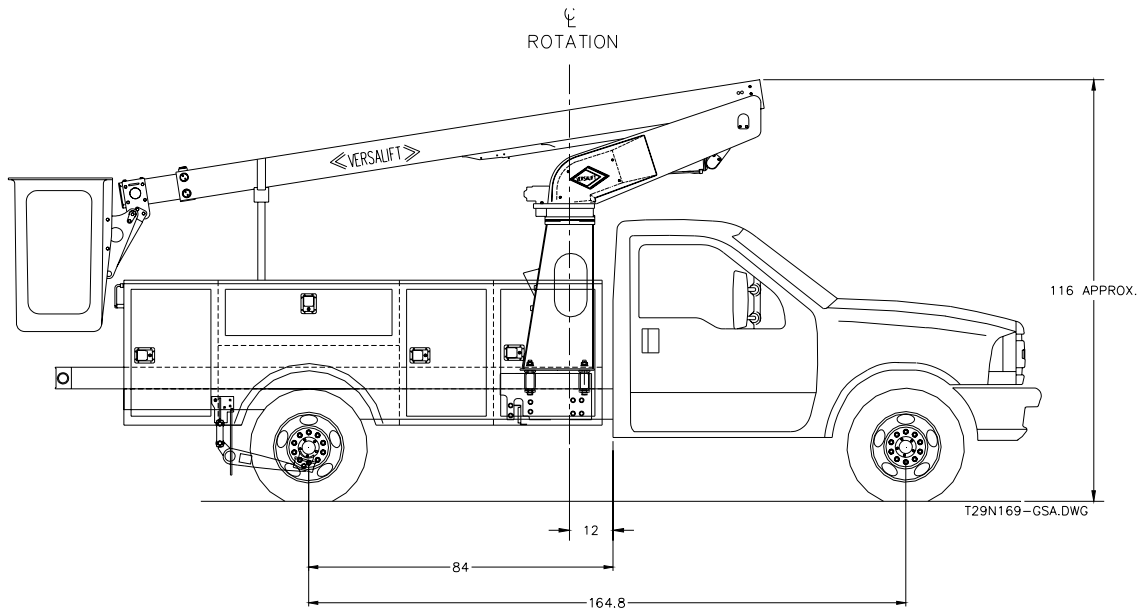

*Versalift Model No.*      **TEL-29-NE**

*Description:*                      Non-insulated, end mounted 28 ft. 9 in. (8.76 m) telescopic aerial platform lift, including 350 lb. platform capacity.

*Chassis Model*                      **FORD F350 4X2**

*Description:*                      11,200 lb. GVWR cab and chassis with 84 inch cab to axle, six (6) speed manual transmission, 5.4L V8 gas engine, AM/FM radio, and no air conditioning.

*Body Model*                          **STEEL SERVICE BODY**

*Description:*                      132 inch steel service body with standard compartments, treadplate tops and floor, and 24 inch tailshelf.

*Installed Items*                      **INSTALLATION**

*Description:*                      Install Versalift Tel-29-NE and service body on chassis. Installation also includes belt drive system, rear torsion bar, and painting body to match chassis.

<b>COMPLETE TOTAL PRICE F.O.B. DESTINATION:</b>	<b>\$ 54,817.00</b>
-------------------------------------------------	---------------------

**TEL-29-NE STANDARD OPTIONS**

Continuous Rotation .....	\$1,815.00
Generator w/Cover .....	\$3,755.00
Splicer Platform .....	\$ 194.00
Tent, Top, Door, Seat, Pouch.....	\$1,048.00
Platform Leveling .....	\$1,195.00
Platform Tilt .....	\$ 374.00
24" x 30" Platform .....	\$ 178.00
Hydraulic Tool Power at Platform (Requires 2-speed throttle) .....	\$ 90.00
Hydraulic Tool Power at Rear (Requires 2-speed throttle) .....	\$ 360.00
One (1) Set of Outriggers in Lieu of Torsion Bars .....	\$2,160.00
Outrigger Boom Interlock .....	\$ 925.00
Two Speed Throttle .....	\$ 447.00
Variable Speed .....	\$ 677.00
Emergency Power .....	\$ 460.00
Air Conditioning-Ford .....	\$1,511.00
Central Locking .....	\$ 280.00
Chock Block Holders .....	\$ 160.00
Compartment Lighting .....	\$ 720.00
Flood Light .....	\$ 616.00
Strobe .....	\$ 418.00
Back Up Alarm .....	\$ 197.00
Pintle & Plug .....	\$ 730.00
Unitrol Single Stick .....	\$ 430.00
Priority Flow Control .....	\$ 530.00
Automatic Transmission-Ford, Gas .....	\$1,195.00
Dimensions 1800W Inverter w/Battery and Cover .....	\$2,454.00

**COLOR BROCHURES AVAILABLE UPON REQUEST  
OR VISIT TIME ON THE WEB AT:  
[WWW.VERSALIFT.COM](http://WWW.VERSALIFT.COM)**

**TEL-29-IH**

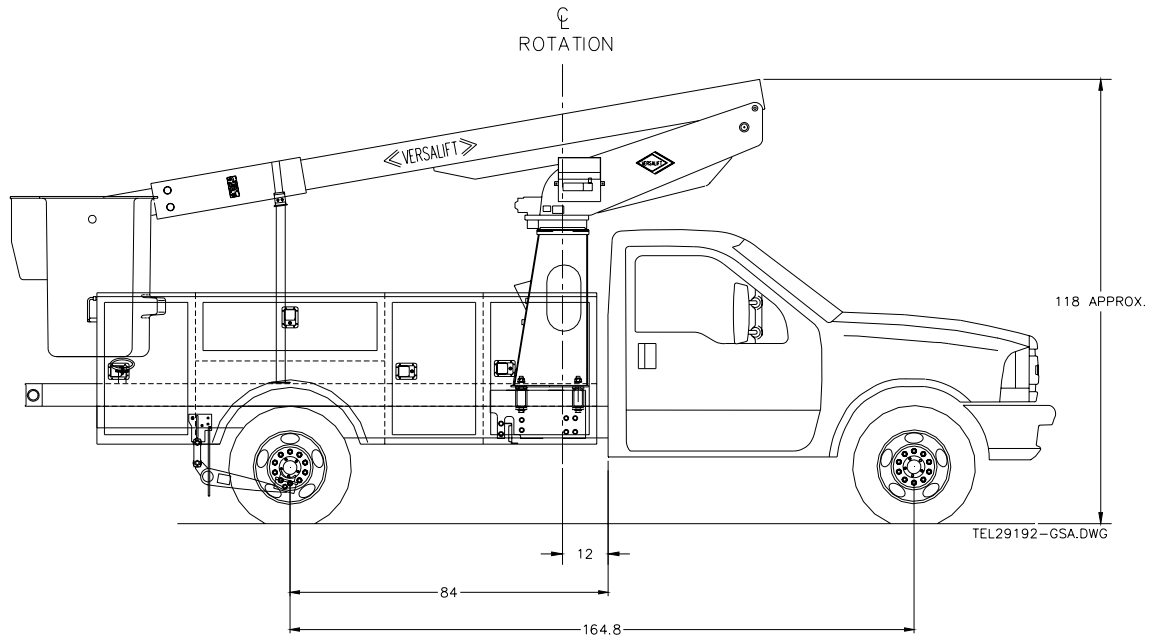

*Versalift Model No.*      **TEL-29-IH**

*Description:*                Insulated, side mounted 28 ft. 9 in. (8.76 m) telescopic aerial platform lift, including 350 lb. platform capacity

*Chassis Model*                **FORD F350 4X2**

*Description:*                11,200 lb. GVWR cab and chassis with 84 inch cab to axle, six (6) speed manual transmission, 5.4L V8 gas engine, AM/FM radio, and no air conditioning.

*Body Model*                    **STEEL SERVICE BODY**

*Description:*                132 inch steel service body with standard compartments, treadplate tops and floor, and 24 inch tailshelf.

*Installed Items*                **INSTALLATION**

*Description:*                Install Versalift Tel-29-IH and service body on chassis. Installation also includes belt drive system, rear torsion bar, and painting body to match chassis.

<b>COMPLETE TOTAL PRICE F.O.B. DESTINATION:</b>	<b>\$ 58,973.00</b>
-------------------------------------------------	---------------------

**TEL-29-IH STANDARD OPTIONS**

Continuous Rotation .....	\$1,815.00
Generator w/Cover .....	\$3,755.00
Splicer Platform .....	\$ 194.00
Tent, Top, Door, Seat, Pouch.....	\$1,048.00
Platform Tilt .....	\$ 374.00
24" x 30" Platform .....	\$ 178.00
Liner & Cover for 24" x 30" Platform.....	\$ 257.00
Hydraulic Tool Power at Platform (Requires 2-speed throttle) .....	\$ 90.00
Hydraulic Tool Power at Rear (Requires 2-speed throttle) .....	\$ 360.00
One (1) Set of Outriggers in Lieu of Torsion Bars .....	\$2,160.00
Outrigger Boom Interlock .....	\$ 925.00
Two Speed Throttle .....	\$ 447.00
Emergency Power .....	\$ 460.00
Air Conditioning-Ford .....	\$1,511.00
Central Locking .....	\$ 280.00
Chock Block Holders .....	\$ 160.00
Compartment Lighting .....	\$ 720.00
Flood Light .....	\$ 616.00
Strobe .....	\$ 418.00
Back Up Alarm .....	\$ 197.00
Pintle & Plug .....	\$ 730.00
Unitrol Single Stick .....	\$ 430.00
Priority Flow Control .....	\$ 530.00
Automatic Transmission-Ford, Gas.....	\$1,195.00

**COLOR BROCHURES AVAILABLE UPON REQUEST  
OR VISIT TIME ON THE WEB AT:  
[WWW.VERSALIFT.COM](http://WWW.VERSALIFT.COM)**

**GSA Contract No. GS-30F-1024H**

**TEL-29-EIH**

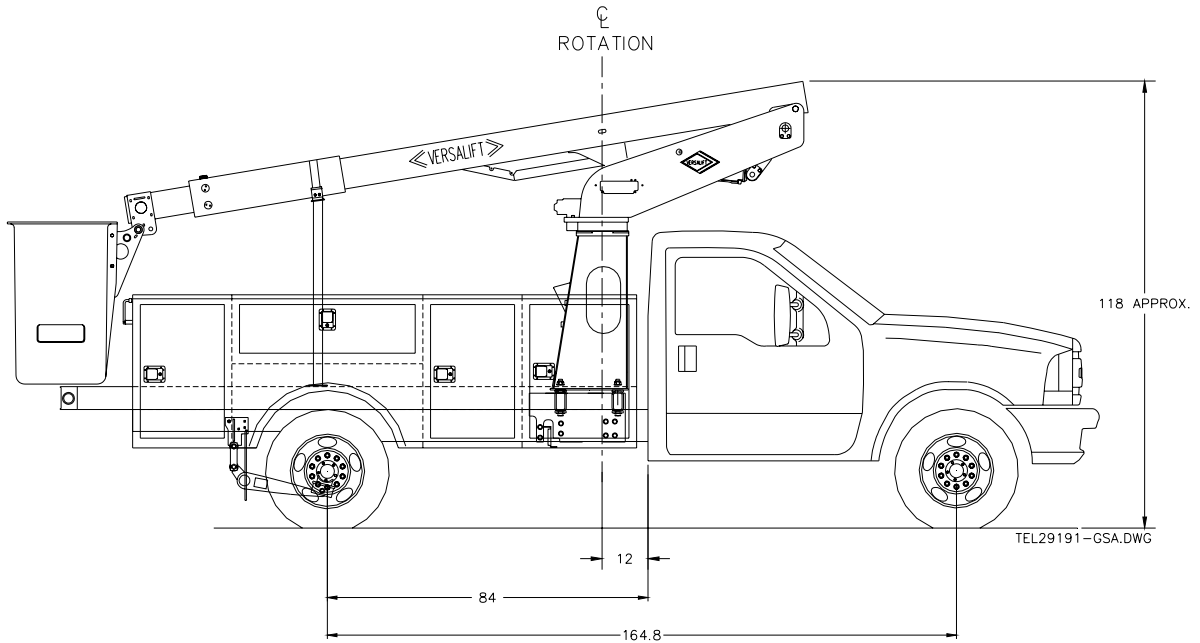

*Versalift Model No.*      **TEL-29-EIH**

*Description:*                Insulated, end mounted 28 ft. 9 in. (8.76 m) telescopic aerial platform lift, including 350 lb. platform capacity.

*Chassis Model*                **FORD F350 4X2**

*Description:*                11,200 lb. GVWR cab and chassis with 84 inch cab to axle, six (6) speed manual transmission, 5.4L V8 gas engine, AM/FM radio, and no air conditioning.

*Body Model*                    **STEEL SERVICE BODY**

*Description:*                132 inch steel service body with standard compartments, treadplate tops and floor, and 24 inch tailshelf.

*Installed Items*                **INSTALLATION**

*Description:*                Install Versalift Tel-29-EIH and service body on chassis. Installation also includes belt drive system, rear torsion bar, and painting body to match chassis.

**COMPLETE TOTAL PRICE F.O.B. DESTINATION:                \$ 59,033.00**

**TEL-29-EIH STANDARD OPTIONS**

Continuous Rotation .....	\$1,815.00
Generator w/Cover .....	\$3,755.00
Splicer Platform .....	\$ 194.00
Tent, Top, Door, Seat, Pouch.....	\$1,048.00
Platform Tilt .....	\$ 374.00
24" x 30" Platform .....	\$ 178.00
Liner & Cover for 24" x 30" Platform.....	\$ 257.00
Hydraulic Tool Power at Platform (Requires 2-speed throttle) .....	\$ 90.00
Hydraulic Tool Power at Rear (Requires 2-speed throttle) .....	\$ 360.00
One (1) Set of Outriggers in Lieu of Torsion Bars .....	\$2,160.00
Outrigger Boom Interlock .....	\$ 925.00
Two Speed Throttle .....	\$ 447.00
Emergency Power .....	\$ 460.00
Air Conditioning-Ford .....	\$1,511.00
Central Locking .....	\$ 280.00
Chock Block Holders .....	\$ 160.00
Compartment Lighting .....	\$ 720.00
Flood Light .....	\$ 616.00
Strobe .....	\$ 418.00
Back Up Alarm .....	\$ 197.00
Pintle & Plug .....	\$ 730.00
Unitrol Single Stick .....	\$ 430.00
Priority Flow Control .....	\$ 530.00
Automatic Transmission-Ford, Gas.....	\$1,195.00

**COLOR BROCHURES AVAILABLE UPON REQUEST  
OR VISIT TIME ON THE WEB AT:  
[WWW.VERSALIFT.COM](http://WWW.VERSALIFT.COM)**



GSA Contract No. GS-30F-1024H

**VANTEL-29-N**

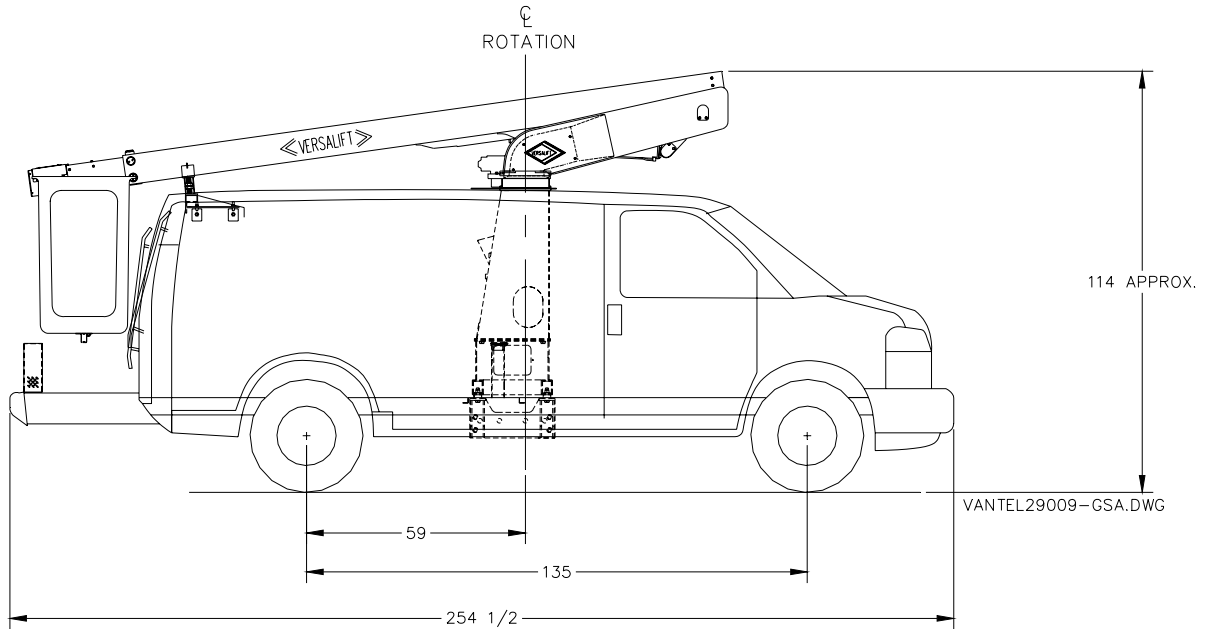

*Versalift Model No.*      **VANTEL-29-N**

*Description:*                Non-insulated, side mounted 28 ft. 10 in. (8.79 m) telescopic aerial platform lift, including 350 lb. platform capacity

*Chassis Model*                **FORD E350 CARGO VAN**

*Description:*                9,600 lb. GVWR cargo van, 138" wheelbase, four (4) speed automatic transmission, 5.4L V8 gas engine, AM/FM radio, and no air conditioning.

*Installed Items*                **INSTALLATION**

*Description:*                Install Versalift VanTel-29-N on cargo van. Installation also includes belt drive system, and painting lift to match van.

**COMPLETE TOTAL PRICE F.O.B. DESTINATION:                \$ 47,167.00**

**VANTEL-29-N STANDARD OPTIONS**

Continuous Rotation .....	\$1,815.00
Generator w/Cover .....	\$3,755.00
Splicer Platform .....	\$ 194.00
Tent, Top, Door, Seat, Pouch.....	\$1,048.00
Platform Leveling .....	\$1,195.00
Two Speed Throttle .....	\$ 447.00
Variable Speed .....	\$ 677.00
Emergency Power .....	\$ 460.00
Ladder Rack for Vantel .....	\$ 526.00
Utility Shelf for Vantel (Adrian #45 Shelf w/Dividers).....	\$ 870.00
Dimensions 1800W Inverter w/Battery and Cover.....	\$2,454.00

**COLOR BROCHURES AVAILABLE UPON REQUEST  
OR VISIT TIME ON THE WEB AT:  
[WWW.VERSALIFT.COM](http://WWW.VERSALIFT.COM)**

### VANTEL-29-IH

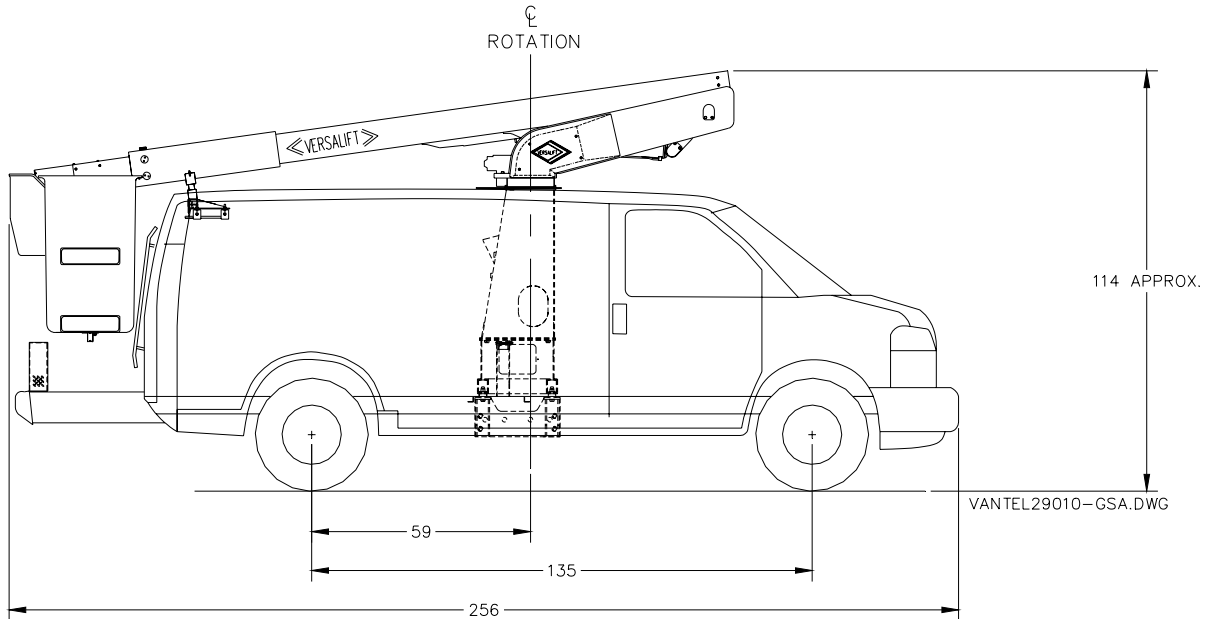

*Versalift Model No.*      **VANTEL-29-IH**

*Description:*              Insulated, side mounted 28 ft. 10 in. (8.79 m) telescopic aerial platform lift, including 350 lb. platform capacity

*Chassis Model*              **FORD E350 CARGO VAN**

*Description:*              9,600 lb. GVWR cargo van, 138" wheelbase, four (4) speed automatic transmission, 5.4L V8 gas engine, AM/FM radio, and no air conditioning.

*Installed Items*              **INSTALLATION**

*Description:*              Install Versalift VanTel-29-IH on cargo van. Installation also includes belt drive system, and painting lift to match van.

<b>COMPLETE TOTAL PRICE F.O.B. DESTINATION:</b>	<b>\$ 51,444.00</b>
-------------------------------------------------	---------------------

**VANTEL-29-IH STANDARD OPTIONS**

Continuous Rotation .....	\$1,815.00
Generator w/Cover .....	\$3,755.00
Splicer Platform .....	\$ 194.00
Tent, Top, Door, Seat, Pouch.....	\$1,048.00
Two Speed Throttle .....	\$ 447.00
Variable Speed .....	\$ 677.00
Emergency Power .....	\$ 460.00
Ladder Rack for Vantel .....	\$ 526.00
Utility Shelf for Vantel (Adrian #45 Shelf w/Dividers).....	\$ 870.00

**COLOR BROCHURES AVAILABLE UPON REQUEST  
OR VISIT TIME ON THE WEB AT:  
[WWW.VERSALIFT.COM](http://WWW.VERSALIFT.COM)**

**ET-32-NF**

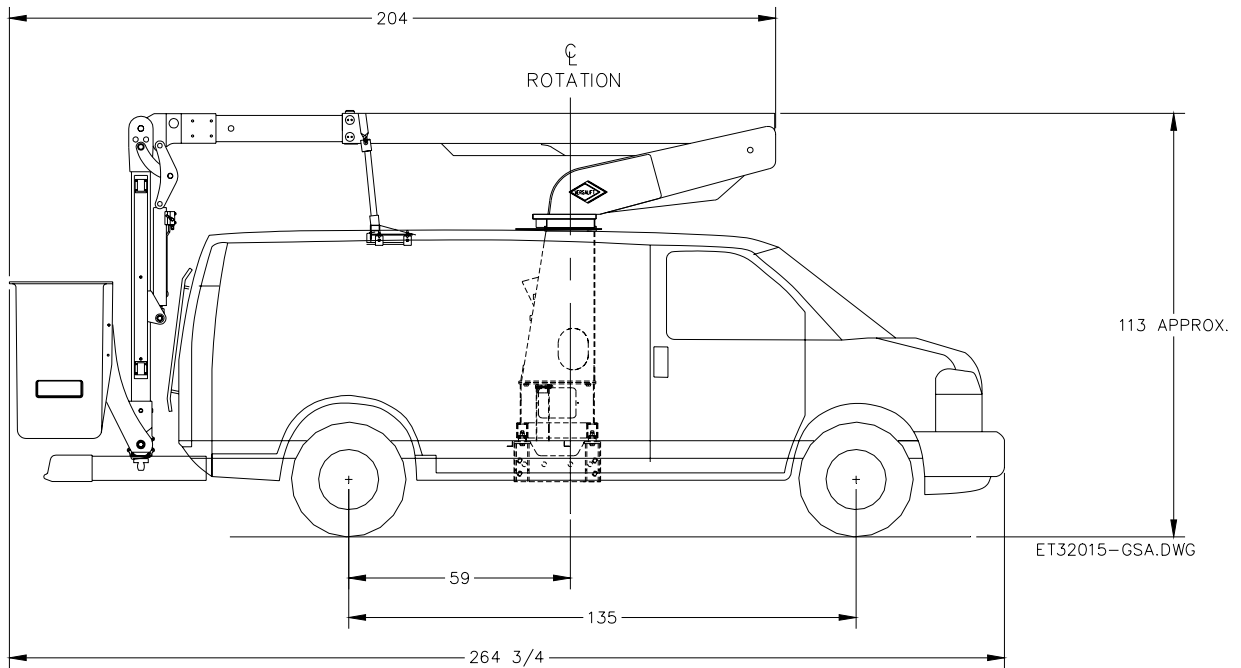

*Versalift Model No.*      **ET-32-NF**

*Description:*                      Non-insulated, 32 ft. 5 in. (9.75 m) telescopic aerial platform lift with 180 degree flyboom, including 300 lb. platform capacity

*Chassis Model*                      **FORD E350 CARGO VAN**

*Description:*                      9,600 lb. GVWR cargo van, 138" wheelbase, four (4) speed automatic transmission, 5.4L V8 gas engine, AM/FM radio, and air conditioning.

*Installed Items*                      **INSTALLATION**

*Description:*                      Install Versalift ET-32-NF on cargo van. Installation also includes belt drive system, and painting lift to match van.

**COMPLETE TOTAL PRICE F.O.B. DESTINATION:                      \$ 56,391.00**

**ET-32-NF STANDARD OPTIONS**

Continuous Rotation .....	\$1,815.00
Generator w/Cover .....	\$3,755.00
Splicer Platform .....	\$ 194.00
Tent, Top, Door, Seat, Pouch.....	\$1,048.00
24" x 30" Platform .....	\$ 178.00
Hydraulic Tool Power at Platform (Requires 2-speed throttle) .....	\$ 90.00
Two Speed Throttle .....	\$ 447.00
Variable Speed .....	\$ 677.00
Emergency Power .....	\$ 460.00
Air Conditioning-Ford .....	\$1,511.00
Strobe .....	\$ 418.00
Back Up Alarm .....	\$ 197.00
Ladder Rack for Vantel .....	\$ 526.00
Utility Shelf for Vantel (Adrian #45 Shelf w/Dividers).....	\$ 870.00
Unitrol Single Stick .....	\$ 430.00
Hydraulic Platform Rotator .....	\$1,229.00
Priority Flow Control .....	\$ 530.00
Dimensions 1800W Inverter w/Battery and Cover.....	\$2,454.00

**COLOR BROCHURES AVAILABLE UPON REQUEST  
OR VISIT TIME ON THE WEB AT:  
[WWW.VERSALIFT.COM](http://WWW.VERSALIFT.COM)**

### T-3100-N

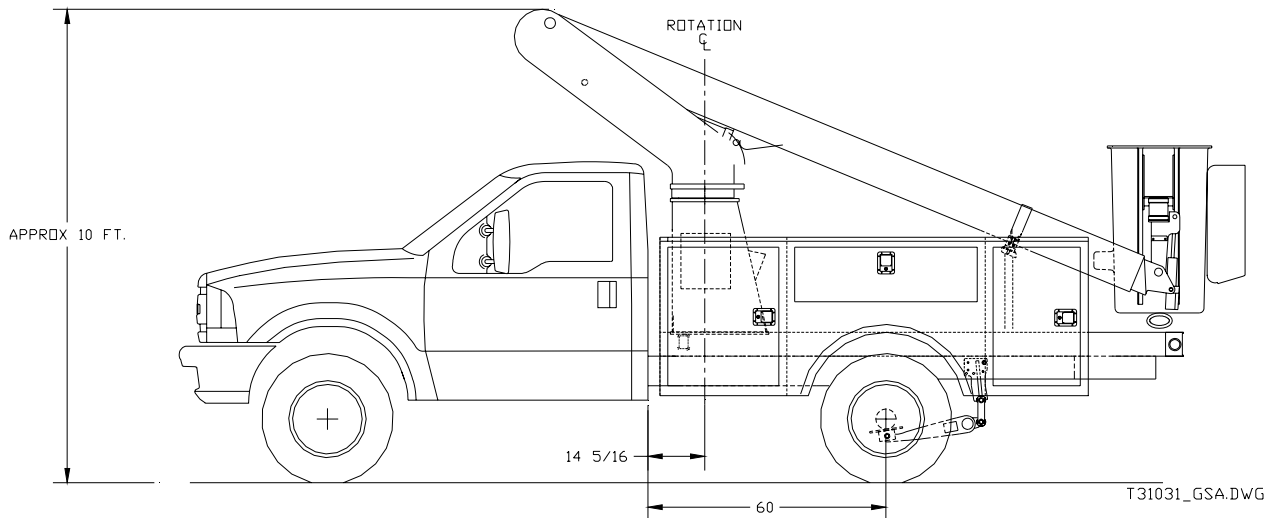

*Versalift Model No.*      **T-3100-N**

*Description:*                Non-insulated, 31 ft. (9.45 m) telescopic aerial platform lift, including 350 lb. platform capacity

*Chassis Model*                **FORD F450 4X2**

*Description:*                15,000 lb. GVWR cab and chassis with 60 inch cab to axle, six (6) speed manual transmission, 6.8L V10 gas engine, AM/FM radio, and no air conditioning.

*Body Model*                    **STEEL SERVICE BODY**

*Description:*                108 inch steel service body with standard compartments, treadplate tops and floor, and 24 inch tailshelf.

*Installed Items*                **INSTALLATION**

*Description:*                Install Versalift T-3100-N and service body on chassis. Installation also includes belt drive system, rear torsion bar, and painting body to match chassis.

<b>COMPLETE TOTAL PRICE F.O.B. DESTINATION:</b>	<b>\$ 64,489.00</b>
-------------------------------------------------	---------------------

**T-3100-N STANDARD OPTIONS**

Generator w/Cover .....	\$3,755.00
24" x 30" Platform .....	\$ 178.00
Hydraulic Tool Power at Platform (Requires 2-speed throttle) .....	\$ 90.00
Hydraulic Tool Power at Rear (Requires 2-speed throttle) .....	\$ 360.00
One (1) Set of Outriggers in Lieu of Torsion Bars .....	\$2,160.00
Outrigger Boom Interlock .....	\$ 925.00
Two Speed Throttle .....	\$ 447.00
Variable Speed .....	\$ 677.00
Emergency Power .....	\$ 460.00
Air Conditioning-Ford .....	\$1,511.00
Central Locking .....	\$ 280.00
Chock Block Holders .....	\$ 160.00
Compartment Lighting .....	\$ 720.00
Flood Light .....	\$ 616.00
Strobe .....	\$ 418.00
Back Up Alarm .....	\$ 197.00
Pintle & Plug .....	\$ 730.00
Unitrol Single Stick .....	\$ 430.00
Priority Flow Control .....	\$ 530.00
Automatic Transmission-Ford, Gas .....	\$1,195.00

**COLOR BROCHURES AVAILABLE UPON REQUEST  
OR VISIT TIME ON THE WEB AT:  
[WWW.VERSALIFT.COM](http://WWW.VERSALIFT.COM)**



**T-3100-I**

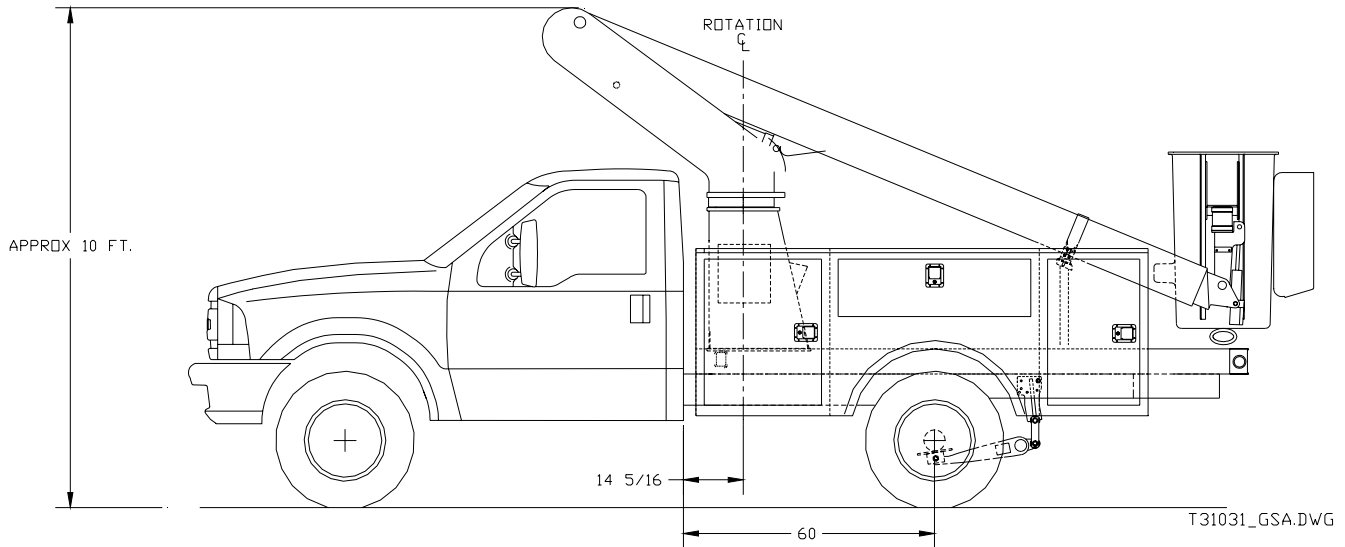

**Versalift Model No. T-3100-I**

**Description:** Insulated, 31 ft. (9.45 m) telescopic aerial platform lift, including 350 lb. platform capacity

**Chassis Model FORD F450 4X2**

**Description:** 15,000 lb. GVWR cab and chassis with 60 inch cab to axle, six (6) speed manual transmission, 6.8L V10 gas engine, AM/FM radio, and no air conditioning.

**Body Model STEEL SERVICE BODY**

**Description:** 108 inch steel service body with standard compartments, treadplate tops and floor, and 24 inch tailshelf.

**Installed Items INSTALLATION**

**Description:** Install Versalift T-3100-I and service body on chassis. Installation also includes belt drive system, rear torsion bar, and painting body to match chassis.

**COMPLETE TOTAL PRICE F.O.B. DESTINATION: \$ 67,428.00**

**T-3100-I STANDARD OPTIONS**

Generator w/Cover .....	\$3,755.00
24" x 30" Platform .....	\$ 178.00
Liner & Cover for 24" x 30" Platform.....	\$ 257.00
Hydraulic Tool Power at Platform (Requires 2-speed throttle) .....	\$ 90.00
Hydraulic Tool Power at Rear (Requires 2-speed throttle) .....	\$ 360.00
One (1) Set of Outriggers in Lieu of Torsion Bars .....	\$2,160.00
Outrigger Boom Interlock .....	\$ 925.00
Two Speed Throttle .....	\$ 447.00
Variable Speed .....	\$ 677.00
Emergency Power .....	\$ 460.00
Air Conditioning-Ford .....	\$1,511.00
Central Locking .....	\$ 280.00
Chock Block Holders .....	\$ 160.00
Compartment Lighting .....	\$ 720.00
Flood Light .....	\$ 616.00
Strobe .....	\$ 418.00
Back Up Alarm .....	\$ 197.00
Pintle & Plug .....	\$ 730.00
Unitrol Single Stick .....	\$ 430.00
Priority Flow Control .....	\$ 530.00
Automatic Transmission-Ford, Gas .....	\$1,195.00
Dimensions 1800W Inverter w/Battery and Cover.....	\$2,454.00

**COLOR BROCHURES AVAILABLE UPON REQUEST  
OR VISIT TIME ON THE WEB AT:  
[WWW.VERSALIFT.COM](http://WWW.VERSALIFT.COM)**

**LT-56-NE**

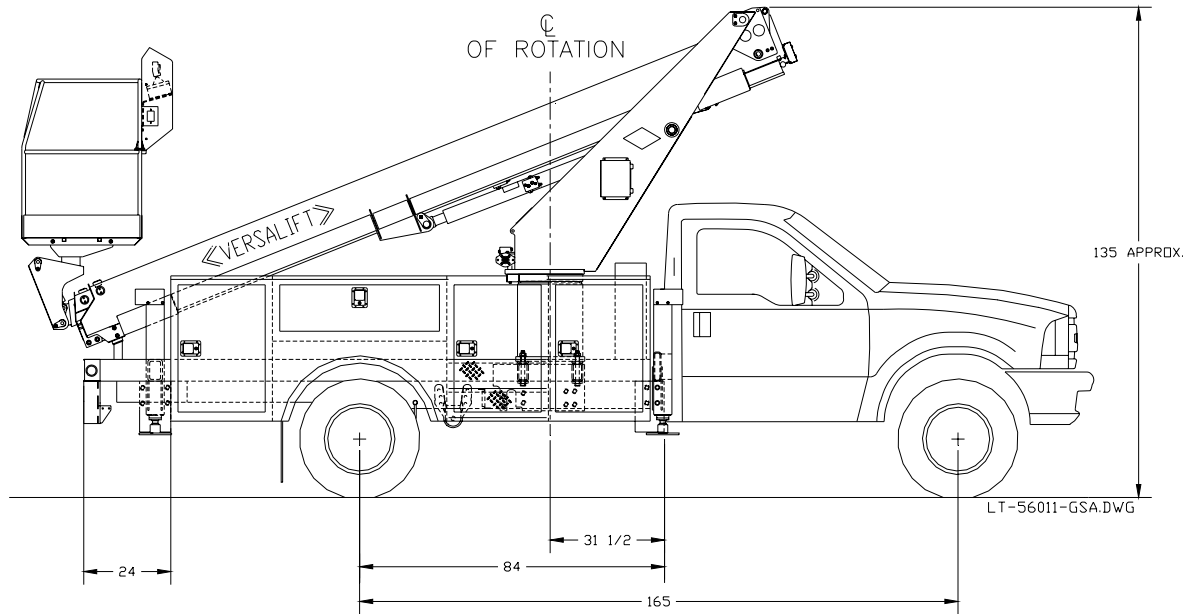

- Versalift Model No.**      **LT-56-NE**
- Description:**              Non-insulated, steel platform, 56 ft. (17.1 m) telescopic aerial platform lift, including 440 lb. platform capacity
- Chassis Model**              **FORD F550 4X2**
- Description:**              17,500 lb. GVWR cab and chassis with 84 inch cab to axle, five (5) speed manual transmission, 6.8L V10 gas engine, AM/FM radio, and no air conditioning.
- Body Model**                 **STEEL SERVICE BODY**
- Description:**              132 inch steel service body with standard compartments, treadplate tops and floor, and 24 inch tailshelf.
- Installed Items**            **INSTALLATION**
- Description:**              Install Versalift LT-56-NE and service body on chassis. Installation also includes PTO and pump, dual H-frame outriggers, and painting body to match chassis.

**COMPLETE TOTAL PRICE F.O.B. DESTINATION:      \$ 97,439.00**

**LT-56-NE STANDARD OPTIONS**

Generator w/Cover .....	\$3,755.00
Outrigger Boom Interlock, Main & Aux. ....	\$1,550.00
Two Speed Throttle .....	\$ 447.00
Air Conditioning-Ford .....	\$1,511.00
Central Locking .....	\$ 280.00
Chock Block Holders .....	\$ 160.00
Compartment Lighting .....	\$ 720.00
Flood Light .....	\$ 616.00
Strobe .....	\$ 418.00
Back Up Alarm .....	\$ 197.00
Pintle & Plug .....	\$ 730.00
Priority Flow Control .....	\$ 530.00
Automatic Transmission-Ford, Gas .....	\$1,195.00
Dimensions 1800W Inverter w/Battery and Cover.....	\$2,454.00

**COLOR BROCHURES AVAILABLE UPON REQUEST  
OR VISIT TIME ON THE WEB AT:  
[WWW.VERSALIFT.COM](http://WWW.VERSALIFT.COM)**

GSA Contract No. GS-30F-1024H

**LT-62-NE**

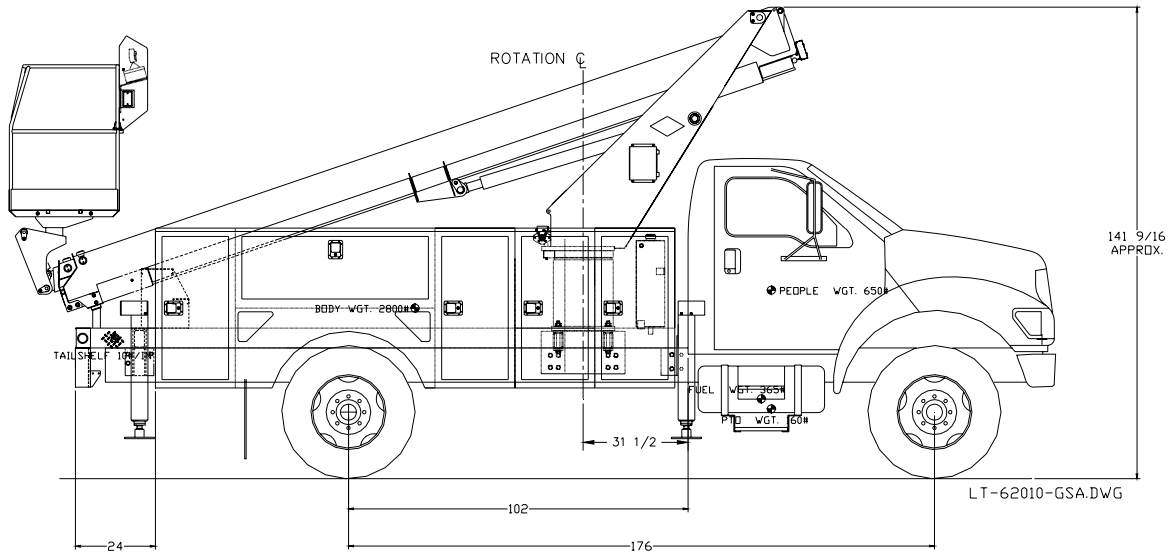

*Versalift Model No.*      **LT-62-NE**

*Description:*                      Non-insulated, steel platform, 62 ft. (18.9 m) telescopic aerial platform lift, including 440 lb. platform capacity

*Chassis Model*                      **FORD F650 4X2**

*Description:*                      26,00 lb. GVWR cab and chassis with 102 inch cab to axle, five (5) speed manual transmission, 6.4L V8 diesel engine, AM/FM radio, and no air conditioning.

*Body Model*                              **STEEL SERVICE BODY**

*Description:*                      156 inch steel line body with standard compartments, treadplate tops and floor, and 24 inch tailshelf.

*Installed Items*                      **INSTALLATION**

*Description:*                      Install Versalift LT-62-NE and service body on chassis. Installation also includes PTO and pump, dual H-frame outriggers, and painting body to match chassis.

**COMPLETE TOTAL PRICE F.O.B. DESTINATION:                      \$119,391.00**

**LT-62-NE STANDARD OPTIONS**

Generator w/Cover .....	\$3,755.00
Outrigger Boom Interlock, Main & Aux. ....	\$1,550.00
Two Speed Throttle .....	\$ 447.00
Air Conditioning-Ford .....	\$1,511.00
Central Locking .....	\$ 280.00
Chock Block Holders .....	\$ 160.00
Compartment Lighting .....	\$ 720.00
Flood Light .....	\$ 616.00
Strobe .....	\$ 418.00
Back Up Alarm .....	\$ 197.00
Pintle & Plug .....	\$ 730.00
Priority Flow Control .....	\$ 530.00
Automatic Transmission-Ford, Diesel.....	\$1,550.00
Dimensions 1800W Inverter w/Battery and Cover.....	\$2,454.00

**COLOR BROCHURES AVAILABLE UPON REQUEST  
OR VISIT TIME ON THE WEB AT:  
[WWW.VERSALIFT.COM](http://WWW.VERSALIFT.COM)**

**GSA Contract No. GS-30F-1024H**

**SST-37-ENH**

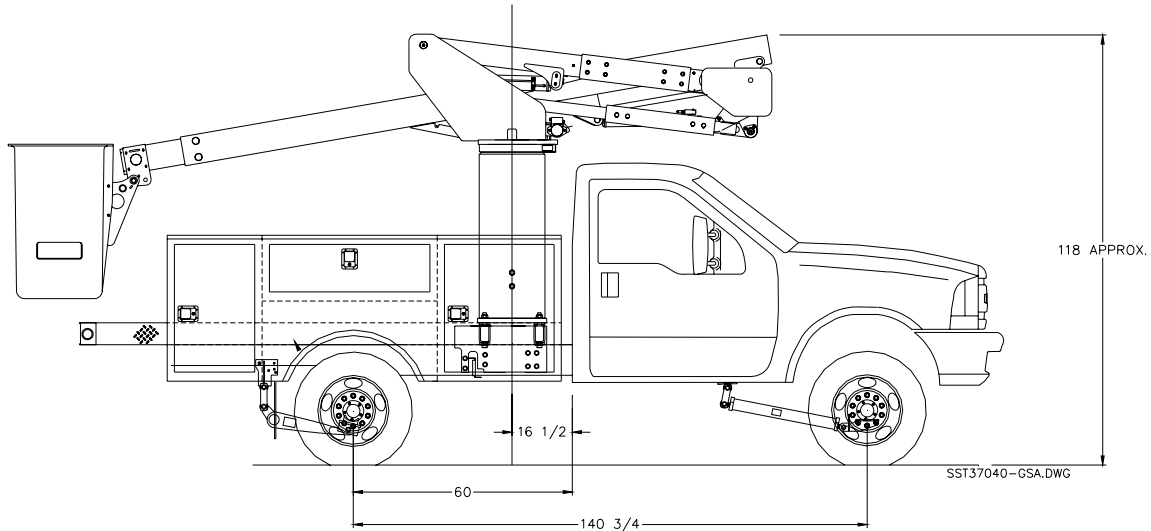

- Versalift Model No. SST-37-ENH**
- Description:** Non-insulated, end mounted 36 ft. 8 in. (11.2 m) telescopic aerial platform lift, including 350 lb. platform capacity
- Chassis Model FORD F450 4X2**
- Description:** 15,000 lb. GVWR cab and chassis with 60 inch cab to axle, six (6) speed manual transmission, 6.8L V10 gas engine, AM/FM radio, and no air conditioning.
- Body Model STEEL SERVICE BODY**
- Description:** 108 inch steel service body with standard compartments, treadplate tops and floor, and 24 inch tailshelf
- Installed Items INSTALLATION**
- Description:** Install Versalift SST-37-ENH and service body on chassis. Installation also includes PTO and pump, front and rear torsion bars, and painting body to match chassis.

<b>COMPLETE TOTAL PRICE F.O.B. DESTINATION:</b>	<b>\$64,978.00</b>
-------------------------------------------------	--------------------

**SST-37-ENH STANDARD OPTIONS**

Generator w/Cover .....	\$3,755.00
24" x 30" Platform .....	\$ 178.00
Hydraulic Tool Power at Platform (Requires 2-speed throttle) .....	\$ 90.00
Hydraulic Tool Power at Rear (Requires 2-speed throttle) .....	\$ 360.00
One (1) Set of Outriggers in Lieu of Torsion Bars .....	\$2,160.00
Outrigger Boom Interlock .....	\$ 460.00
Air Conditioning-Ford .....	\$1,511.00
Emergency Power .....	\$ 460.00
Central Locking .....	\$ 280.00
Chock Block Holders .....	\$ 160.00
Compartment Lighting .....	\$ 720.00
Flood Light .....	\$ 616.00
Strobe .....	\$ 418.00
Back Up Alarm .....	\$ 197.00
Pintle & Plug .....	\$ 730.00
Hydraulic Platform Rotator .....	\$1,229.00
Automatic Transmission-Ford, Gas .....	\$1,195.00
Dimensions 1800W Inverter w/Battery and Cover.....	\$2,454.00

**COLOR BROCHURES AVAILABLE UPON REQUEST  
OR VISIT TIME ON THE WEB AT:  
[WWW.VERSALIFT.COM](http://WWW.VERSALIFT.COM)**



**SST-37-EIH**

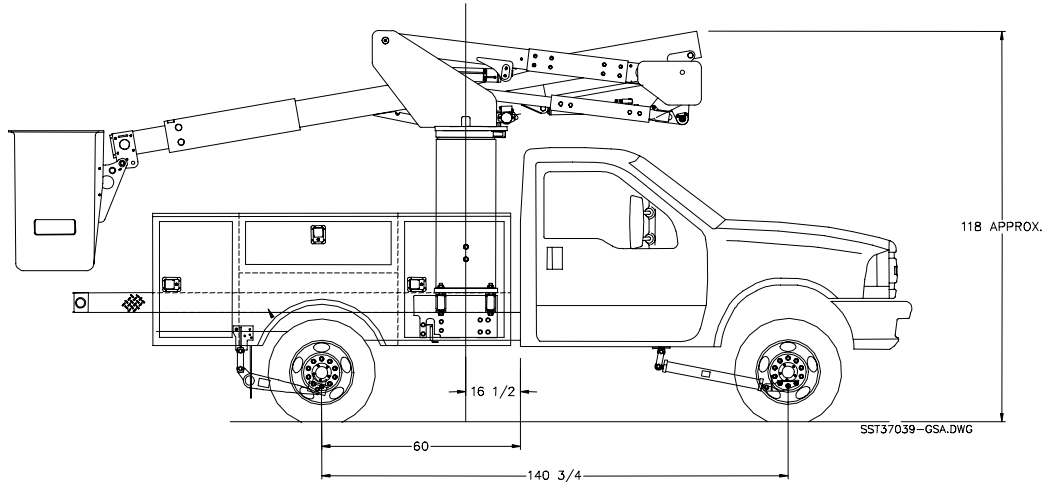

**Versalift Model No. SST-37-EIH**

**Description:** Insulated, end mounted 36 ft. 8 in. (11.2 m) telescopic aerial platform lift, including 350 lb. platform capacity.

**Chassis Model FORD F450 4X2**

**Description:** 15,000 lb. GVWR cab and chassis with 60 inch cab to axle, six (6) speed manual transmission, 6.8L V10 gas engine, AM/FM radio, and no air conditioning.

**Body Model STEEL SERVICE BODY**

**Description:** 108 inch steel service body with standard compartments, treadplate tops and floor, and 24 inch tailshelf.

**Installed Items INSTALLATION**

**Description:** Install Versalift SST-37-EIH and service body on chassis. Installation also includes PTO and pump, front and rear torsion bars, and painting body to match chassis.

<b>COMPLETE TOTAL PRICE F.O.B. DESTINATION:</b>	<b>\$67,927.00</b>
-------------------------------------------------	--------------------

**SST-37-EIH STANDARD OPTIONS**

Generator w/Cover .....	\$3,755.00
24" x 30" Platform .....	\$ 178.00
Liner & Cover for 24" x 30" Platform.....	\$ 257.00
Hydraulic Tool Power at Rear (Requires 2-speed throttle) .....	\$ 360.00
One (1) Set of Outriggers in Lieu of Torsion Bars .....	\$2,160.00
Outrigger Boom Interlock .....	\$ 925.00
Emergency Power .....	\$ 460.00
Air Conditioning-Ford .....	\$1,511.00
Central Locking .....	\$ 280.00
Chock Block Holders .....	\$ 160.00
Compartment Lighting .....	\$ 720.00
Flood Light .....	\$ 616.00
Strobe .....	\$ 418.00
Back Up Alarm .....	\$ 197.00
Pintle & Plug .....	\$ 730.00
Hydraulic Platform Rotator .....	\$1,229.00
Automatic Transmission-Ford, Gas .....	\$1,195.00

**COLOR BROCHURES AVAILABLE UPON REQUEST  
OR VISIT TIME ON THE WEB AT:  
[WWW.VERSALIFT.COM](http://WWW.VERSALIFT.COM)**

**SST-40-EIH**

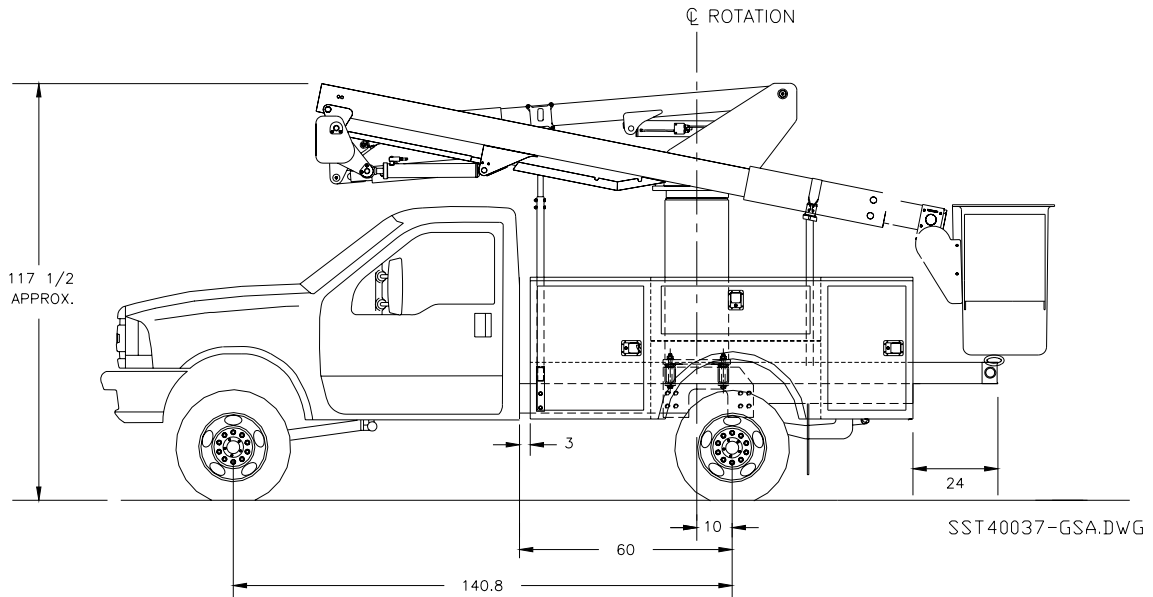

**Versalift Model No. SST-40-EIH**

**Description:** Insulated, end mounted 39 ft. 8 in. (12.1 m) telescopic aerial platform lift, including 350 lb. platform capacity.

**Chassis Model FORD F450 4X2**

**Description:** 15,000 lb. GVWR cab and chassis with 60 inch cab to axle, six (6) speed manual transmission, 6.8L V10 gas engine, AM/FM radio, and no air conditioning.

**Body Model STEEL SERVICE BODY**

**Description:** 108 inch steel service body with standard compartments, treadplate tops and floor, and 24 inch tailshelf.

**Installed Items INSTALLATION**

**Description:** Install Versalift SST-40-EIH and service body on chassis. Installation also includes PTO and pump, front and rear torsion bars, and painting body to match chassis.

**COMPLETE TOTAL PRICE F.O.B. DESTINATION: \$68,820.00**

**SST-40-EIH STANDARD OPTIONS**

Generator w/Cover .....	\$3,755.00
24" x 30" Platform .....	\$ 178.00
Liner & Cover for 24" x 30" Platform.....	\$ 257.00
Hydraulic Tool Power at Platform (Requires 2-speed throttle) .....	\$ 90.00
Hydraulic Tool Power at Rear (Requires 2-speed throttle) .....	\$ 360.00
One (1) Set of Outriggers in Lieu of Torsion Bars .....	\$2,160.00
Outrigger Boom Interlock .....	\$ 925.00
Emergency Power .....	\$ 460.00
Air Conditioning-Ford .....	\$1,511.00
Central Locking .....	\$ 280.00
Chock Block Holders .....	\$ 160.00
Compartment Lighting .....	\$ 720.00
Flood Light .....	\$ 616.00
Strobe .....	\$ 418.00
Back Up Alarm .....	\$ 197.00
Pintle & Plug .....	\$ 730.00
Hydraulic Platform Rotator .....	\$1,229.00
Automatic Transmission-Ford, Gas.....	\$1,195.00

**COLOR BROCHURES AVAILABLE UPON REQUEST  
OR VISIT TIME ON THE WEB AT:  
[WWW.VERSALIFT.COM](http://WWW.VERSALIFT.COM)**

**VST-36-N**

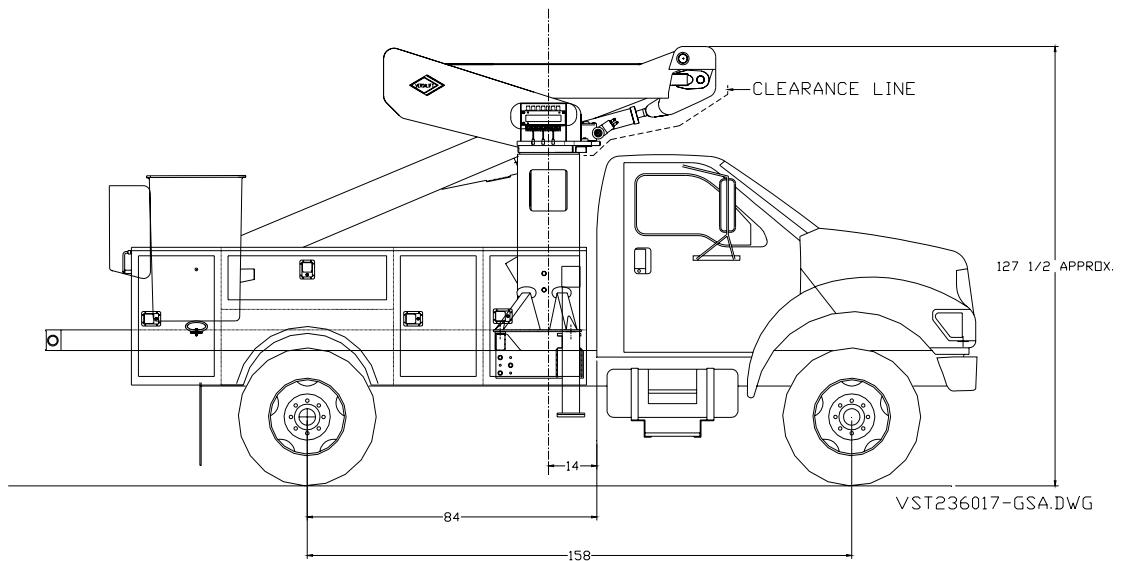

*Versalift Model No.*      **VST-36-N**

*Description:*                      Non-insulated, side mounted 36 ft. (11.00 m) telescopic aerial platform lift, including 350 lb. platform capacity.

*Chassis Model*                      **FORD F650 4X2**

*Description:*                      26,000 lb. GVWR cab and chassis with 84 inch cab to axle, five (5) speed manual transmission, 6.4L V8 diesel engine, AM/FM radio, and no air conditioning.

*Body Model*                          **STEEL SERVICE BODY**

*Description:*                      132 inch steel service body with standard compartments, treadplate tops and floor, and 24 inch tailshelf.

*Installed Items*                      **INSTALLATION**

*Description:*                      Install Versalift VST-36-N and service body on chassis. Installation also includes PTO and pump, A-frame outriggers, and painting body to match chassis.

<b>COMPLETE TOTAL PRICE F.O.B. DESTINATION:</b>	<b>\$94,844.00</b>
-------------------------------------------------	--------------------

**VST-36-N STANDARD OPTIONS**

Generator w/Cover .....	\$3,755.00
24" x 30" Platform .....	\$ 178.00
Hydraulic Tool Power at Rear (Requires 2-speed throttle) .....	\$ 360.00
Outrigger Boom Interlock .....	\$ 925.00
Emergency Power .....	\$ 460.00
Air Conditioning-Ford .....	\$1,511.00
Central Locking .....	\$ 280.00
Chock Block Holders .....	\$ 160.00
Compartment Lighting .....	\$ 720.00
Flood Light .....	\$ 616.00
Strobe .....	\$ 418.00
Back Up Alarm .....	\$ 197.00
Pintle & Plug .....	\$ 730.00
Automatic Transmission-Ford, Diesel.....	\$1,550.00
Dimensions 1800W Inverter w/Battery and Cover .....	\$2,454.00
Material Handling Jib and Winch.....	\$3,170.00

**COLOR BROCHURES AVAILABLE UPON REQUEST  
OR VISIT TIME ON THE WEB AT:  
[WWW.VERSALIFT.COM](http://WWW.VERSALIFT.COM)**

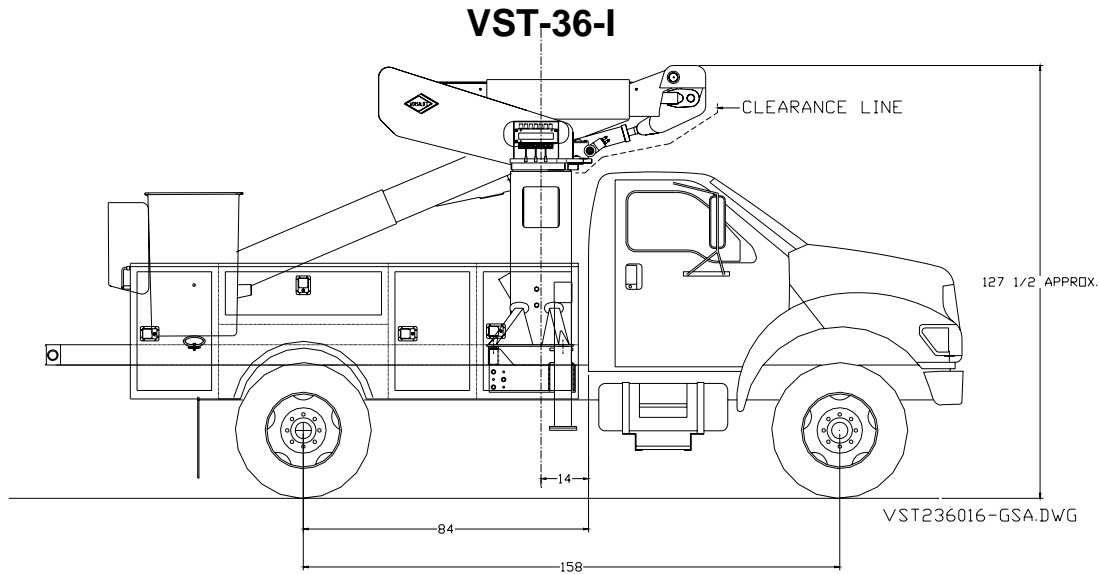

**Versalift Model No. VST-36-I**

**Description:** Insulated, side mounted 36 ft. (11.00 m) telescopic aerial platform lift, including 350 lb. platform capacity

**Chassis Model FORD F650 4X2**

**Description:** 26,000 lb. GVWR cab and chassis with 84 inch cab to axle, five (5) speed manual transmission, 6.4L V8 diesel engine, AM/FM radio, and no air conditioning.

**Body Model STEEL SERVICE BODY**

**Description:** 132 inch steel service body with standard compartments, treadplate tops and floor, and 24 inch tailshelf.

**Installed Items INSTALLATION**

**Description:** Install Versalift VST-36-I and service body on chassis. Installation also includes PTO and pump, A-frame outriggers, and painting body to match chassis.

**COMPLETE TOTAL PRICE F.O.B. DESTINATION: \$99,065.00**

**VST-36-I STANDARD OPTIONS**

Generator w/Cover .....	\$3,755.00
24" x 30" Platform .....	\$ 178.00
Liner & Cover for 24" x 30" Platform.....	\$ 257.00
Hydraulic Tool Power at Rear (Requires 2-speed throttle) .....	\$ 360.00
Outrigger Boom Interlock .....	\$ 925.00
Emergency Power .....	\$ 460.00
Material Handling Jib/Winch.....	\$3,170.00
Air Conditioning-Ford .....	\$1,511.00
Central Locking .....	\$ 280.00
Chock Block Holders .....	\$ 160.00
Compartment Lighting .....	\$ 720.00
Flood Light .....	\$ 616.00
Strobe .....	\$ 418.00
Back Up Alarm .....	\$ 197.00
Pintle & Plug .....	\$ 730.00
Automatic Transmission-Ford, Diesel.....	\$1,550.00

**COLOR BROCHURES AVAILABLE UPON REQUEST  
OR VISIT TIME ON THE WEB AT:  
[WWW.VERSALIFT.COM](http://WWW.VERSALIFT.COM)**



**VST-40-N**

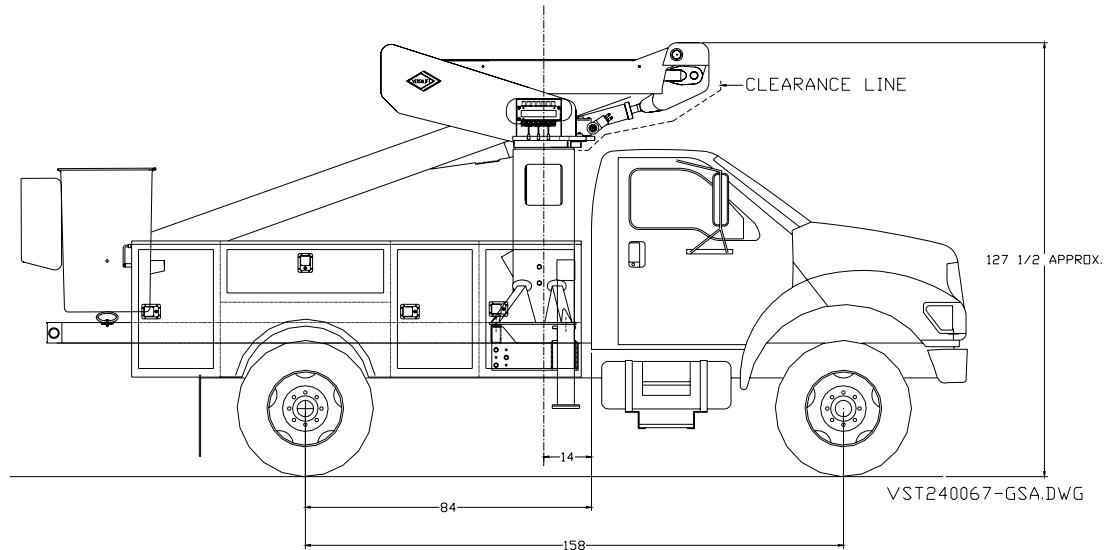

*Versalift Model No.*      **VST-40-N**

*Description:*              Non-insulated, side mounted 40 ft. (12.2 m) telescopic aerial platform lift, including 350 lb. platform capacity.

*Chassis Model*              **FORD F650 4X2**

*Description:*              26,000 lb. GVWR cab and chassis with 84 inch cab to axle, five (5) speed manual transmission, 6.4L V8 diesel engine, AM/FM radio, and no air conditioning.

*Body Model*                 **STEEL SERVICE BODY**

*Description:*              132 inch steel service body with standard compartments, treadplate tops and floor, and 24 inch tailshelf.

*Installed Items*            **INSTALLATION**

*Description:*              Install Versalift VST-40-N and service body on chassis. Installation also includes PTO and pump, A-frame outriggers, and painting body to match chassis.

<b>COMPLETE TOTAL PRICE F.O.B. DESTINATION:</b>	<b>\$95,757.00</b>
-------------------------------------------------	--------------------

**VST-40-N STANDARD OPTIONS**

Generator w/Cover .....	\$3,755.00
24" x 30" Platform .....	\$ 178.00
Hydraulic Tool Power at Rear (Requires 2-speed throttle) .....	\$ 360.00
Outrigger Boom Interlock .....	\$ 925.00
Emergency Power .....	\$ 460.00
Material Handling Jib/Winch.....	\$3,170.00
Air Conditioning-Ford .....	\$1,511.00
Central Locking .....	\$ 280.00
Chock Block Holders .....	\$ 160.00
Compartment Lighting .....	\$ 720.00
Flood Light .....	\$ 616.00
Strobe .....	\$ 418.00
Back Up Alarm .....	\$ 197.00
Pintle & Plug .....	\$ 730.00
Automatic Transmission-Ford, Diesel.....	\$1,550.00
Dimensions 1800W Inverter w/Battery and Cover.....	\$2,454.00

**COLOR BROCHURES AVAILABLE UPON REQUEST  
OR VISIT TIME ON THE WEB AT:  
[WWW.VERSALIFT.COM](http://WWW.VERSALIFT.COM)**

## VST-40-I

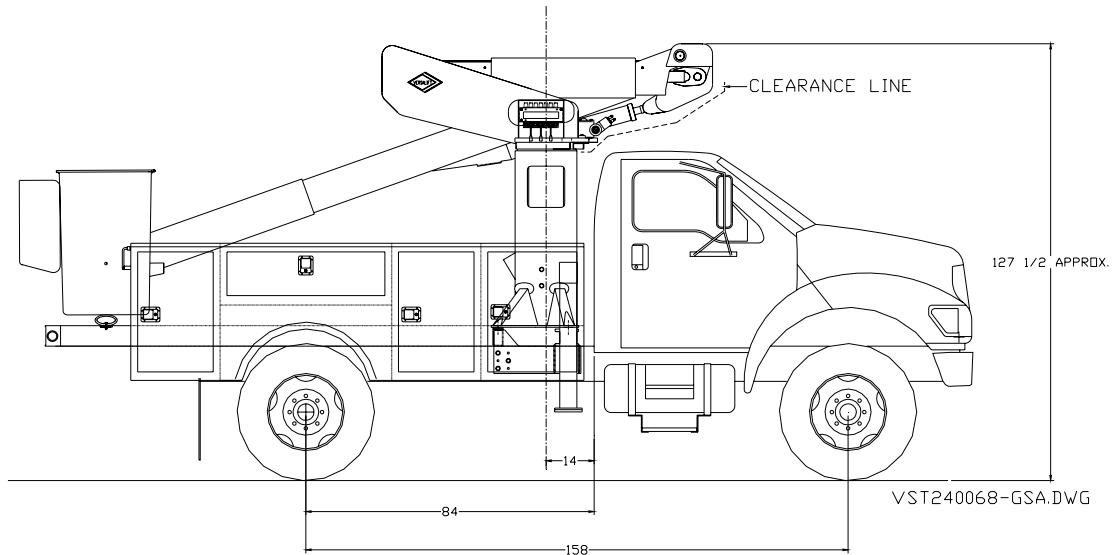

*Versalift Model No.*      **VST-40-I**

*Description:*              Insulated, side mounted 40 ft. (12.2 m) telescopic aerial platform lift, including 350 lb. platform capacity.

*Chassis Model*              **FORD F650 4X2**

*Description:*              26,000 lb. GVWR cab and chassis with 84 inch cab to axle, five (5) speed manual transmission, 6.4L V8 diesel engine, AM/FM radio, and no air conditioning.

*Body Model*                 **STEEL SERVICE BODY**

*Description:*              132 inch steel service body with standard compartments, treadplate tops and floor, and 24 inch tailshelf.

*Installed Items*            **INSTALLATION**

*Description:*              Install Versalift VST-40-I and service body on chassis. Installation also includes PTO and pump, A-frame outriggers, and painting body to match chassis.

**COMPLETE TOTAL PRICE F.O.B. DESTINATION:              \$100,086.00**

**VST-40-I STANDARD OPTIONS**

Generator w/Cover .....	\$3,755.00
24" x 30" Platform .....	\$ 178.00
Liner & Cover for 24" x 30" Platform.....	\$ 257.00
Hydraulic Tool Power at Rear (Requires 2-speed throttle) .....	\$ 360.00
Outrigger Boom Interlock .....	\$ 925.00
Emergency Power .....	\$ 460.00
Material Handling Jib/Winch.....	\$3,170.00
Air Conditioning-Ford .....	\$1,511.00
Central Locking .....	\$ 280.00
Chock Block Holders .....	\$ 160.00
Compartment Lighting .....	\$ 720.00
Flood Light .....	\$ 616.00
Strobe .....	\$ 418.00
Back Up Alarm .....	\$ 197.00
Pintle & Plug .....	\$ 730.00
Automatic Transmission-Ford, Diesel.....	\$1,550.00

**COLOR BROCHURES AVAILABLE UPON REQUEST  
OR VISIT TIME ON THE WEB AT:  
[WWW.VERSALIFT.COM](http://WWW.VERSALIFT.COM)**

### VST-5000-I

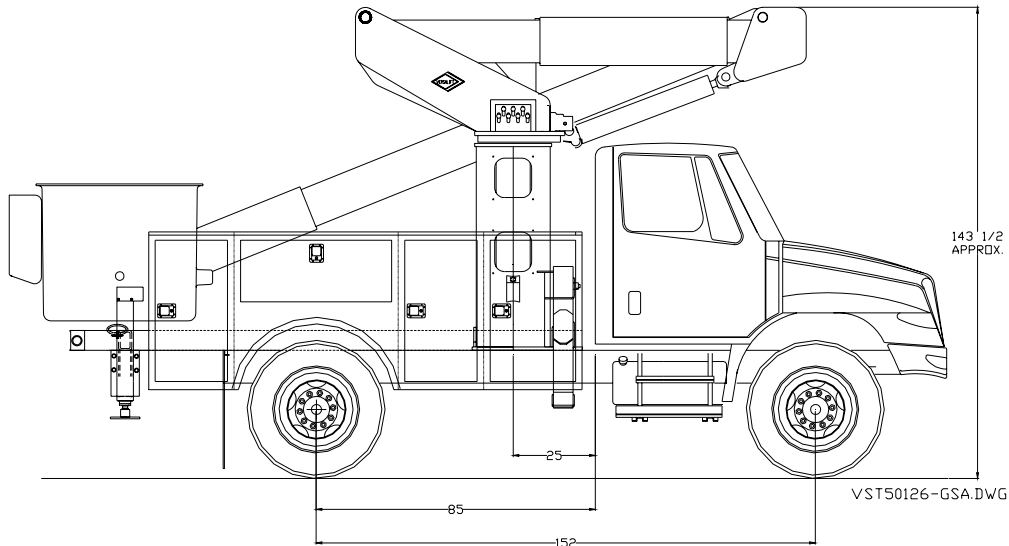

*Versalift Model No.*      **VST-5000-I**

*Description:*              Insulated, side mounted 50 ft. (15.2 m) telescopic aerial platform lift, including 600 lb. platform capacity.

*Chassis Model*              **INTERNATIONAL 4300 4X2**

*Description:*              33,000 lb. GVWR cab and chassis with 84 inch cab to axle, six (6) speed manual transmission, MaxxForce diesel engine, AM/FM radio, and air conditioning.

*Body Model*                 **STEEL SERVICE BODY**

*Description:*              132 inch steel line body with standard compartments, treadplate tops and floor, and 24 inch tailshelf.

*Installed Items*            **INSTALLATION**

*Description:*              Install Versalift VST-5000-I and line body on chassis. Installation also includes PTO and pump, pedestal mounted A-frame and auxiliary H-frame outriggers, and painting body to match chassis.

<b>COMPLETE TOTAL PRICE F.O.B. DESTINATION:</b>	<b>\$133,991.00</b>
-------------------------------------------------	---------------------

**VST-5000-I STANDARD OPTIONS**

Hydraulic Tool Power at Platform (Requires 2-speed throttle) .....	\$ 90.00
Hydraulic Tool Power at Rear (Requires 2-speed throttle) .....	\$ 360.00
Outrigger Boom Interlock, Main & Aux. ....	\$1,550.00
Emergency Power .....	\$ 460.00
Material Handling Jib/Winch.....	\$3,170.00
Central Locking .....	\$ 280.00
Chock Block Holders .....	\$ 160.00
Compartment Lighting .....	\$ 720.00
Flood Light .....	\$ 616.00
Strobe .....	\$ 418.00
Back Up Alarm .....	\$ 197.00
Pintle & Plug .....	\$ 730.00
Automatic Transmission-International .....	\$6,250.00
Hydraulic Material Handling Jib and Winch .....	\$4,562.00

**COLOR BROCHURES AVAILABLE UPON REQUEST  
OR VISIT TIME ON THE WEB AT:  
[WWW.VERSALIFT.COM](http://WWW.VERSALIFT.COM)**

**VST-5500-I**

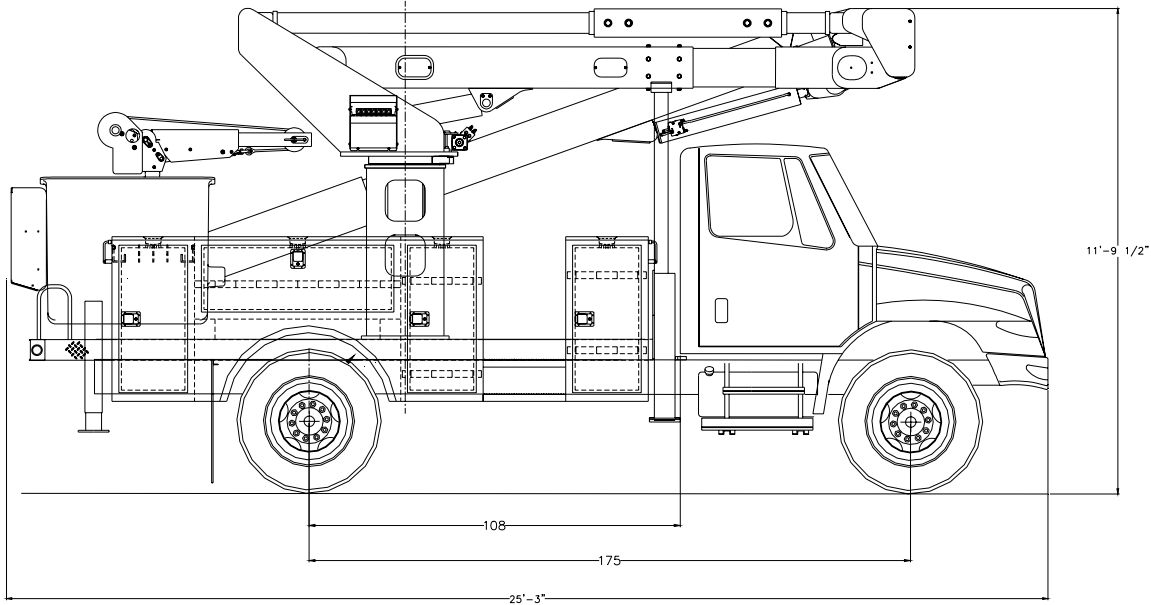

*Versalift Model No.*      **VST-5500-I**

*Description:*                Insulated, side mounted 55 ft. (16.7 m) telescopic aerial platform lift, including 600 lb. platform capacity.

*Chassis Model*                **INTERNATIONAL 4300 4X2**

*Description:*                33,000 lb. GVWR cab and chassis with 108 inch cab to axle, six (6) speed manual transmission, MaxxFoer diesel engine, AM/FM radio, and air conditioning.

*Body Model*                    **STEEL SERVICE BODY**

*Description:*                156 inch steel line body with standard compartments, treadplate tops and floor, and 24 inch tailshelf.

*Installed Items*                **INSTALLATION**

*Description:*                Install Versalift VST-5500-I and line body on chassis. Installation also includes PTO and pump, pedestal mounted A-frame and auxiliary H-frame outriggers, and painting body to match chassis.

<b>COMPLETE TOTAL PRICE F.O.B. DESTINATION:</b>	<b>\$143,897.00</b>
-------------------------------------------------	---------------------

**VST-5500-I STANDARD OPTIONS**

Hydraulic Tool Power at Platform (Requires 2-speed throttle) .....	\$ 90.00
Hydraulic Tool Power at Rear (Requires 2-speed throttle) .....	\$ 360.00
Outrigger Boom Interlock, Main & Aux. ....	\$1,550.00
Emergency Power .....	\$ 460.00
Material Handling Jib/Winch.....	\$3,170.00
Central Locking .....	\$ 280.00
Chock Block Holders .....	\$ 160.00
Compartment Lighting .....	\$ 720.00
Flood Light .....	\$ 616.00
Strobe .....	\$ 418.00
Back Up Alarm .....	\$ 197.00
Pintle & Plug .....	\$ 730.00
Automatic Transmission-International .....	\$6,250.00
Hydraulic Material Handling Jib and Winch .....	\$4,562.00

**COLOR BROCHURES AVAILABLE UPON REQUEST  
OR VISIT TIME ON THE WEB AT:  
[WWW.VERSALIFT.COM](http://WWW.VERSALIFT.COM)**



**VST-6000-I**

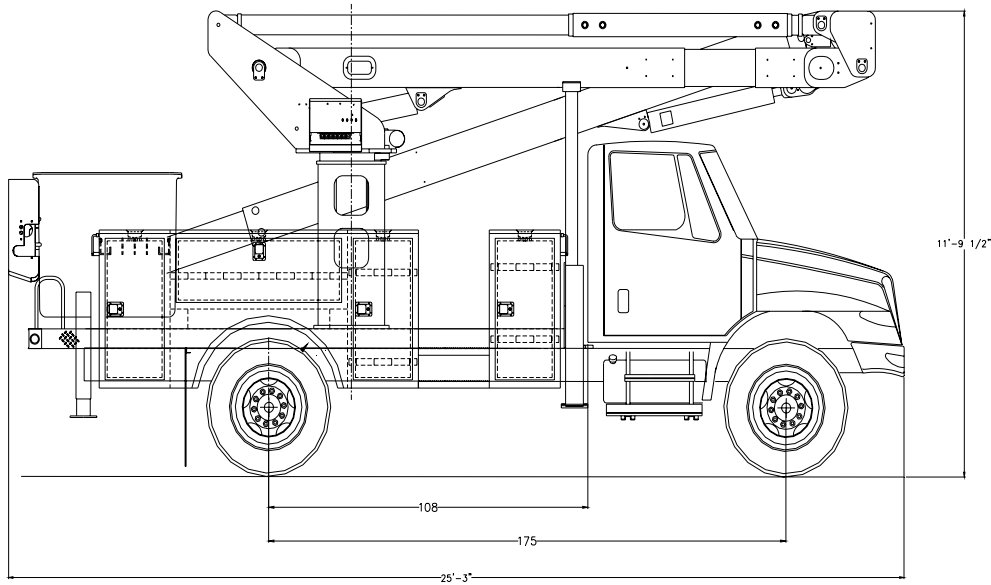

*Versalift Model No.*      **VST-6000-I**

*Description:*                Insulated, side mounted 60 ft. (18.3 m) telescopic aerial platform lift, including 600 lb. platform capacity.

*Chassis Model*                **INTERNATIONAL 4300 4X2**

*Description:*                33,000 lb. GVWR cab and chassis with 108 inch cab to axle, six (6) speed manual transmission, MaxxFORCE diesel engine, AM/FM radio, and air conditioning.

*Body Model*                    **STEEL SERVICE BODY**

*Description:*                156 inch steel line body with standard compartments, treadplate tops and floor, and 24 inch tailshelf.

*Installed Items*                **INSTALLATION**

*Description:*                Install Versalift VST-6000-I and line body on chassis. Installation also includes PTO and pump, pedestal mounted A-frame and auxiliary H-frame outriggers, and painting body to match chassis.

<b>COMPLETE TOTAL PRICE F.O.B. DESTINATION:</b>	<b>\$148,447.00</b>
-------------------------------------------------	---------------------

**VST-6000-I STANDARD OPTIONS**

Hydraulic Tool Power at Platform (Requires 2-speed throttle) .....	\$ 90.00
Hydraulic Tool Power at Rear (Requires 2-speed throttle) .....	\$ 360.00
Outrigger Boom Interlock, Main & Aux. ....	\$1,550.00
Emergency Power .....	\$ 460.00
Material Handling Jib/Winch.....	\$3,170.00
Central Locking .....	\$ 280.00
Chock Block Holders .....	\$ 160.00
Compartment Lighting .....	\$ 720.00
Flood Light .....	\$ 616.00
Strobe .....	\$ 418.00
Back Up Alarm .....	\$ 197.00
Pintle & Plug .....	\$ 730.00
Automatic Transmission-International .....	\$6,250.00
Hydraulic Material Handling Jib and Winch .....	\$4,562.00

**COLOR BROCHURES AVAILABLE UPON REQUEST  
OR VISIT TIME ON THE WEB AT:  
[WWW.VERSALIFT.COM](http://WWW.VERSALIFT.COM)**

**GSA Contract No. GS-30F-1024H**

**VN-55-I**

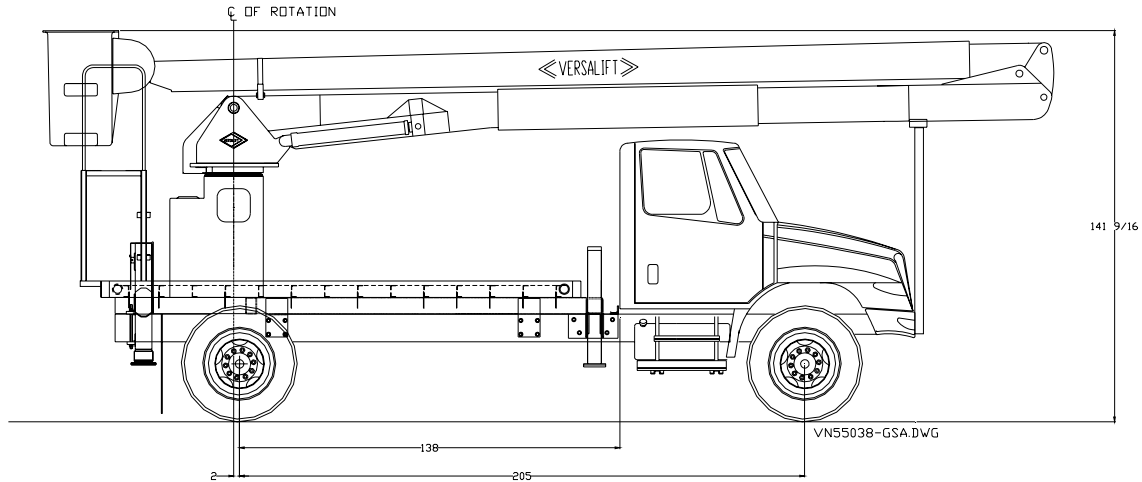

*Versalift Model No.*      **VN-55-I**

*Description:*                Insulated, side mounted 55 ft. (16.8 m) non-overcenter, articulated aerial platform lift, including 700 lb. platform capacity

*Chassis Model*                **INTERNATIONAL 4300 4X2**

*Description:*                33,000 lb. GVWR cab and chassis with 138 inch cab to axle, six (6) speed manual transmission, MAXXFORCE diesel engine, AM/FM radio, and air conditioning.

*Body Model*                    **FLATBED**

*Description:*                Fourteen (14) foot heavy duty flatbed with treadplate floor.

*Installed Items*                **INSTALLATION**

*Description:*                Install Versalift VN-55-I and flatbed on chassis. Installation also includes PTO and pump, dual A-frame outriggers, and painting body to match chassis.

<b>COMPLETE TOTAL PRICE F.O.B. DESTINATION:</b>	<b>\$120,343.00</b>
-------------------------------------------------	---------------------

**VN-55-I STANDARD OPTIONS**

Platform Leveling .....	\$1,195.00
24" x 30" Platform .....	\$ 178.00
Liner & Cover for 24" x 30" Platform.....	\$ 257.00
Hydraulic Tool Power at Platform (Requires 2-speed throttle) .....	\$ 90.00
Hydraulic Tool Power at Rear (Requires 2-speed throttle) .....	\$ 360.00
Outrigger Boom Interlock, Main & Aux. ....	\$1,550.00
Two Speed Throttle .....	\$ 447.00
Emergency Power .....	\$ 460.00
Chock Block Holders .....	\$ 160.00
Flood Light .....	\$ 616.00
Strobe .....	\$ 418.00
Back Up Alarm .....	\$ 197.00
Pintle & Plug .....	\$ 730.00
Unitrol Single Stick .....	\$ 430.00
Hydraulic Platform Rotator .....	\$1,229.00
Automatic Transmission-International .....	\$6,250.00

**COLOR BROCHURES AVAILABLE UPON REQUEST  
OR VISIT TIME ON THE WEB AT:  
[WWW.VERSALIFT.COM](http://WWW.VERSALIFT.COM)**

**VO-36-I**

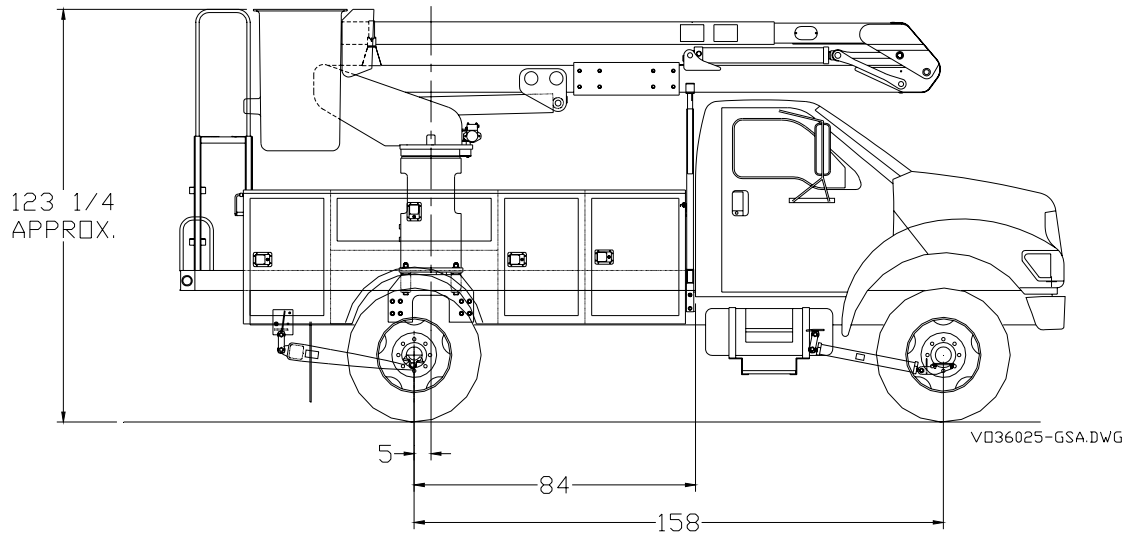

*Versalift Model No.*      **VO-36-I**

*Description:*                Insulated, side mounted 36 ft. (11.0 m) overcenter, articulated aerial platform lift, including 300 lb. platform capacity.

*Chassis Model*                **FORD F650 4X2**

*Description:*                26,000 lb. GVWR cab and chassis with 84 inch cab to axle, five (5) speed manual transmission, 6.4L V8 diesel engine, AM/FM radio, and no air conditioning.

*Body Model*                    **STEEL SERVICE BODY**

*Description:*                132 inch steel service body with standard compartments, treadplate tops and floor, and 24 inch tailshelf.

*Installed Items*                **INSTALLATION**

*Description:*                Install Versalift VO-36-I and service body on chassis. Installation also includes PTO and pump, front and rear torsion bars, and painting body to match chassis.

**COMPLETE TOTAL PRICE F.O.B. DESTINATION:      \$88,106.00**

**VO-36-I STANDARD OPTIONS**

Platform Tilt .....	\$ 374.00
24" x 30" Platform .....	\$ 178.00
Liner & Cover for 24" x 30" Platform.....	\$ 257.00
Hydraulic Tool Power at Platform (Requires 2-speed throttle) .....	\$ 90.00
Hydraulic Tool Power at Rear (Requires 2-speed throttle) .....	\$ 360.00
One (1) Set of Outriggers in Lieu of Torsion Bars .....	\$2,160.00
Outrigger Boom Interlock, Main & Aux. ....	\$1,550.00
Emergency Power .....	\$ 460.00
Air Conditioning-Ford .....	\$1,511.00
Central Locking .....	\$ 280.00
Chock Block Holders .....	\$ 160.00
Compartment Lighting .....	\$ 720.00
Flood Light .....	\$ 616.00
Strobe .....	\$ 418.00
Back Up Alarm .....	\$ 197.00
Pintle & Plug .....	\$ 730.00
Unitrol Single Stick .....	\$ 430.00
Automatic Transmission-Ford, Diesel.....	\$1,550.00

**COLOR BROCHURES AVAILABLE UPON REQUEST  
OR VISIT TIME ON THE WEB AT:  
[WWW.VERSALIFT.COM](http://WWW.VERSALIFT.COM)**

**VO-40-MHI**

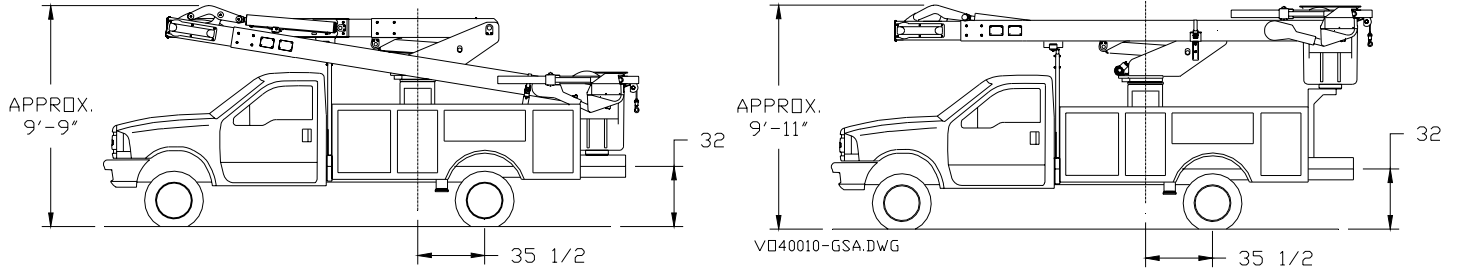

Versalift Model No. **VO-40-MHI**

Description: Insulated, side mounted 39 ft. 10 in. (12.1 m) overcenter, articulated, material handling aerial platform lift, including 350 lb. platform capacity.

Chassis Model **FORD F550 4X2**

Description: 17,500 lb. GVWR cab and chassis with 84 inch cab to axle, five (5) speed manual transmission, 6.8L V10 gas engine, AM/FM radio, and no air conditioning.

Body Model **STEEL SERVICE BODY**

Description: 132 inch steel service body with standard compartments, treadplate tops and floor, and 24 inch tailshelf.

Installed Items **INSTALLATION**

Description: Install Versalift VO-40-MHI and service body on chassis. Installation also includes PTO and pump, A-frame outriggers, and painting body to match chassis.

<b>COMPLETE TOTAL PRICE F.O.B. DESTINATION:</b>	<b>\$84,966.00</b>
-------------------------------------------------	--------------------

**VO-40-MHI STANDARD OPTIONS**

Generator w/Cover .....	\$3,755.00
24" x 30" Platform .....	\$ 178.00
Liner & Cover for 24" x 30" Platform.....	\$ 257.00
Hydraulic Tool Power at Rear (Requires 2-speed throttle) .....	\$ 360.00
Outrigger Boom Interlock .....	\$ 925.00
Emergency Power .....	\$ 460.00
Air Conditioning-Ford .....	\$1,511.00
Central Locking .....	\$ 280.00
Chock Block Holders .....	\$ 160.00
Compartment Lighting .....	\$ 720.00
Flood Light .....	\$ 616.00
Strobe .....	\$ 418.00
Back Up Alarm .....	\$ 197.00
Pintle & Plug .....	\$ 730.00
Automatic Transmission-Ford, Gas.....	\$1,195.00

**COLOR BROCHURES AVAILABLE UPON REQUEST  
OR VISIT TIME ON THE WEB AT:  
[WWW.VERSALIFT.COM](http://WWW.VERSALIFT.COM)**

**GSA Contract No. GS-30F-1024H**



**VO-43-I**

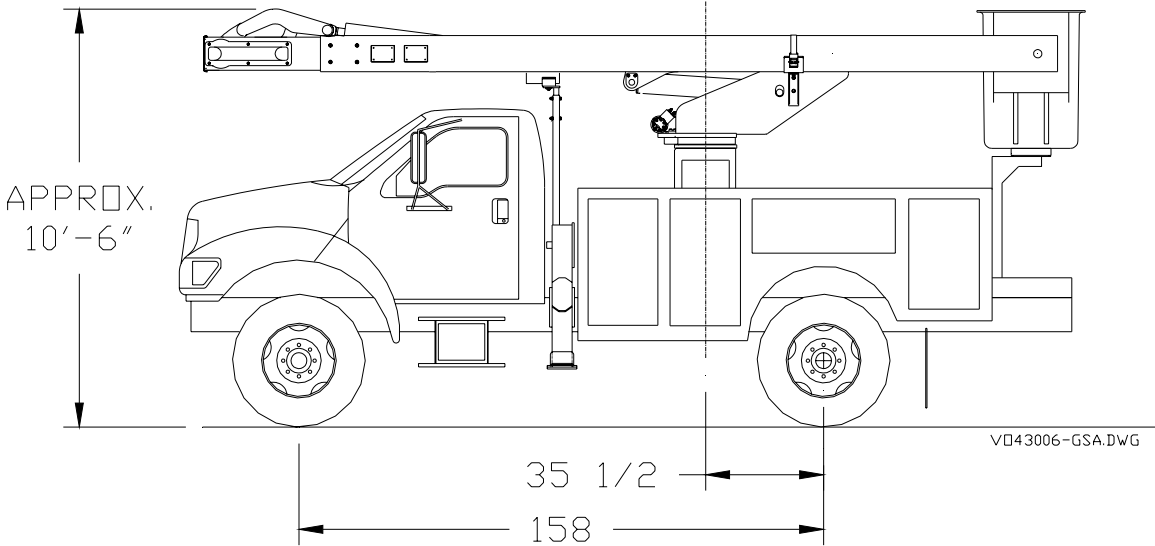

**Versalift Model No. VO-43-I**

**Description:** Insulated, side mounted 42 ft. 10 in.(13.0 m) overcenter, articulated aerial platform lift, including 350 lb. platform capacity.

**Chassis Model FORD F650 4X2**

**Description:** 26,000 lb. GVWR cab and chassis with 84 inch cab to axle, five (5) speed manual transmission, 6.4L V8 diesel engine, AM/FM radio, and no air conditioning.

**Body Model STEEL SERVICE BODY**

**Description:** 132 inch steel service body with standard compartments, treadplate tops and floor, and 24 inch tailshelf.

**Installed Items INSTALLATION**

**Description:** Install Versalift VO-43-I and service body on chassis. Installation also includes PTO and pump, A-frame outriggers, and painting body to match chassis.

**COMPLETE TOTAL PRICE F.O.B. DESTINATION: \$96,219.00**

**VO-43-I STANDARD OPTIONS**

Generator w/Cover .....	\$3,755.00
Platform Tilt .....	\$ 374.00
24" x 30" Platform .....	\$ 178.00
Liner & Cover for 24" x 30" Platform.....	\$ 257.00
Hydraulic Tool Power at Rear (Requires 2-speed throttle) .....	\$ 360.00
Outrigger Boom Interlock .....	\$ 925.00
Two Speed Throttle .....	\$ 447.00
Emergency Power .....	\$ 460.00
Air Conditioning-Ford .....	\$1,511.00
Central Locking .....	\$ 280.00
Chock Block Holders .....	\$ 160.00
Compartment Lighting .....	\$ 720.00
Flood Light .....	\$ 616.00
Strobe .....	\$ 418.00
Back Up Alarm .....	\$ 197.00
Pintle & Plug .....	\$ 730.00
Priority Flow Control .....	\$ 530.00
Automatic Transmission-Ford, Diesel.....	\$1,550.00

**COLOR BROCHURES AVAILABLE UPON REQUEST  
OR VISIT TIME ON THE WEB AT:  
[WWW.VERSALIFT.COM](http://WWW.VERSALIFT.COM)**

## VO-255-I

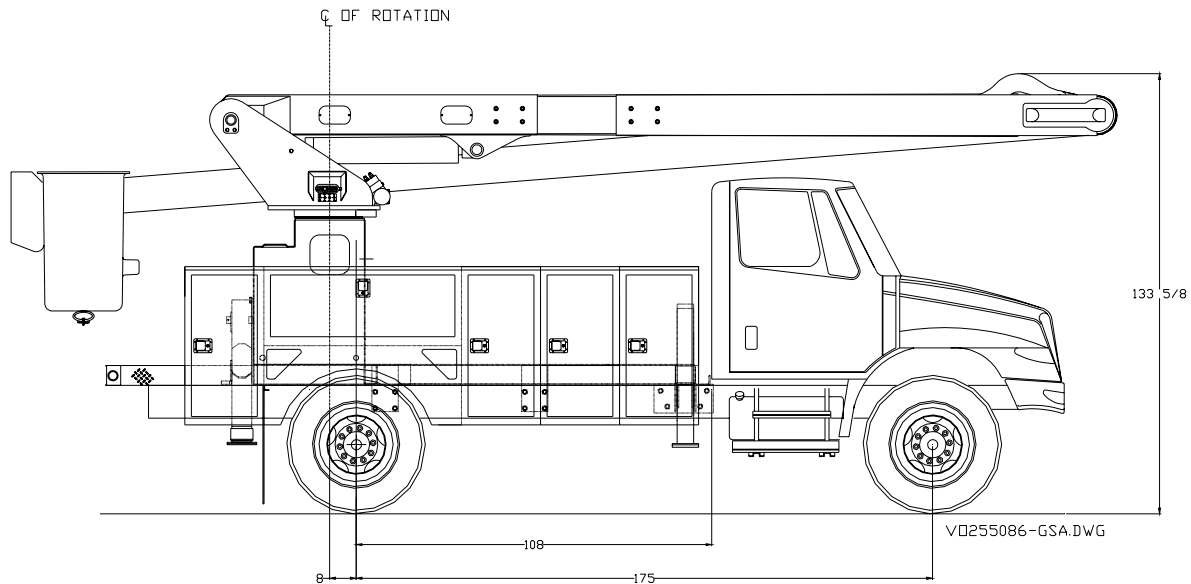

*Versalift Model No.*      **VO-255-I**

*Description:*                Insulated, side mounted 55 ft. (16.8 m) overcenter, articulated aerial platform lift, including 350 lb. platform capacity.

*Chassis Model*                **INTERNATIONAL 4300 4X2**

*Description:*                33,000 lb. GVWR cab and chassis with 108 inch cab to axle, six (6) speed manual transmission, MaxxForce diesel engine, AM/FM radio, and air conditioning.

*Body Model*                    **STEEL SERVICE BODY**

*Description:*                156 inch steel line body with standard compartments, treadplate tops and floor, and 24" tailshelf.

*Installed Items*                **INSTALLATION**

*Description:*                Install Versalift VO-255-I and line body on chassis. Installation also includes PTO and pump, A-frame outriggers, and painting body to match chassis.

**COMPLETE TOTAL PRICE F.O.B. DESTINATION:                \$126,576.00**

**VO-255-I STANDARD OPTIONS**

Platform Tilt .....	\$ 374.00
24" x 30" Platform .....	\$ 178.00
Liner & Cover for 24" x 30" Platform.....	\$ 257.00
Hydraulic Tool Power at Rear (Requires 2-speed throttle) .....	\$ 360.00
Outrigger Boom Interlock, Main & Aux. ....	\$1,550.00
Emergency Power .....	\$ 460.00
Central Locking .....	\$ 280.00
Chock Block Holders .....	\$ 160.00
Compartment Lighting .....	\$ 720.00
Flood Light .....	\$ 616.00
Strobe .....	\$ 418.00
Back Up Alarm .....	\$ 197.00
Pintle & Plug .....	\$ 730.00
Unitrol Single Stick .....	\$ 430.00
Automatic Transmission-International .....	\$6,250.00

**COLOR BROCHURES AVAILABLE UPON REQUEST  
OR VISIT TIME ON THE WEB AT:  
[WWW.VERSALIFT.COM](http://WWW.VERSALIFT.COM)**

**VO-255-I**  
(Chipper/Forestry)

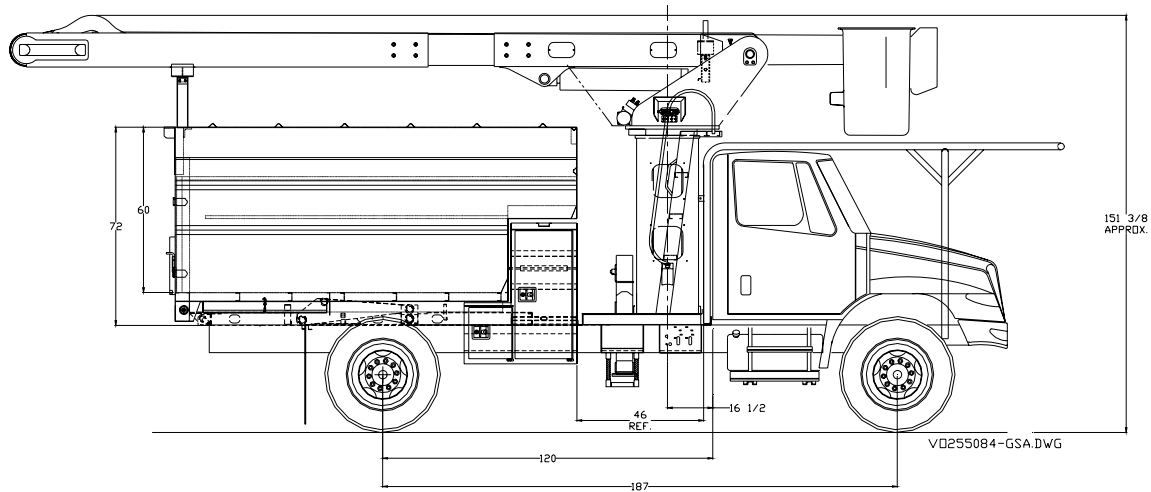

*Versalift Model No.*      **VO-255-I**

*Description:*                      Insulated, side mounted 55 ft. (16.8 m) overcenter, articulated aerial platform lift, including 350 lb. platform capacity.

*Chassis Model*                      **INTERNATIONAL 4300 4X2**

*Description:*                      33,000 lb. GVWR cab and chassis with 120 inch cab to axle, six (6) speed manual transmission, MaxxFace diesel engine, AM/FM radio, and air conditioning.

*Body Model*                          **CHIPPER/FORESTRY BODY**

*Description:*                      146 inch long chipper body with cab guard, hoist, L shaped box, ladder box, and swing to side tailgate.

*Installed Items*                      **INSTALLATION**

*Description:*                      Install Versalift VO-255-I and chipper body on chassis. Installation also includes PTO and pump, A-frame outriggers, and painting body to match chassis.

<b>COMPLETE TOTAL PRICE F.O.B. DESTINATION:</b>	<b>\$128,745.00</b>
-------------------------------------------------	---------------------

**VO-255-I (Chipper/Forestry) STANDARD OPTIONS**

Platform Tilt .....	\$ 374.00
24" x 30" Platform .....	\$ 178.00
Liner & Cover for 24" x 30" Platform.....	\$ 257.00
Hydraulic Tool Power at Rear (Requires 2-speed throttle) .....	\$ 360.00
Outrigger Boom Interlock .....	\$ 925.00
Emergency Power .....	\$ 460.00
Chock Block Holders .....	\$ 160.00
Flood Light .....	\$ 616.00
Strobe .....	\$ 418.00
Back Up Alarm .....	\$ 197.00
Pintle & Plug .....	\$ 730.00
Unitrol Single Stick .....	\$ 430.00
Automatic Transmission-International .....	\$6,250.00

**COLOR BROCHURES AVAILABLE UPON REQUEST  
OR VISIT TIME ON THE WEB AT:  
[WWW.VERSALIFT.COM](http://WWW.VERSALIFT.COM)**

**VO-260-I**  
(Chipper/Forestry)

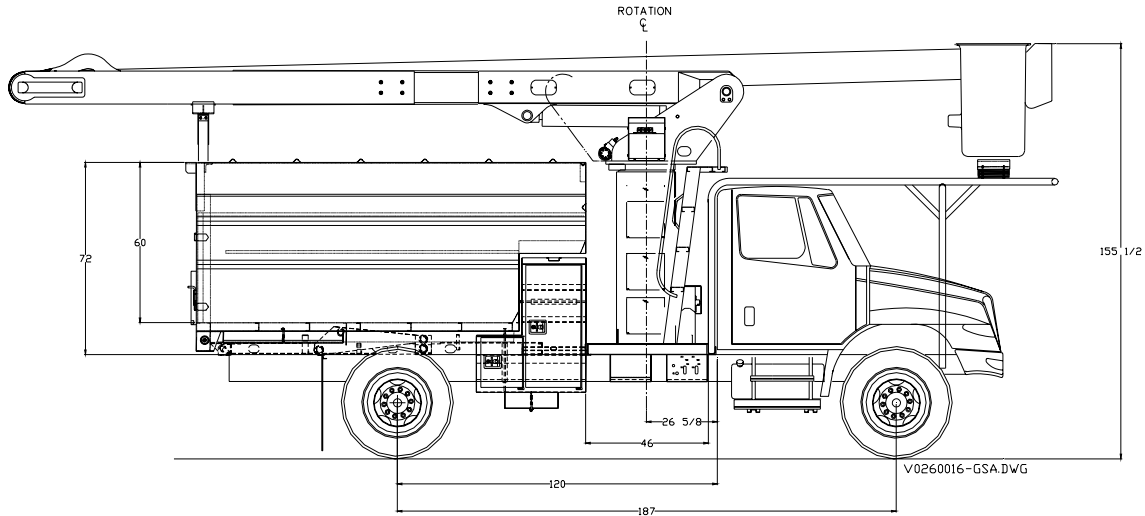

*Versalift Model No.*      **VO-260-I**

*Description:*                Insulated, side mounted 60 ft. (18.3 m) overcenter, articulated aerial platform lift, including 350 lb. platform capacity.

*Chassis Model*                **INTERNATIONAL 4300 4X2**

*Description:*                33,000 lb. GVWR cab and chassis with 120 inch cab to axle, six (6) speed manual transmission, MaxxForce diesel engine, AM/FM radio, and air conditioning.

*Body Model*                    **CHIPPER/FORESTRY BODY**

*Description:*                146 inch long chipper body with cab guard, hoist, L shaped box, ladder box, and swing to side tailgate.

*Installed Items*                **INSTALLATION**

*Description:*                Install Versalift VO-260-I and chipper body on chassis. Installation also includes PTO and pump, A-frame outriggers, and painting body to match chassis.

**COMPLETE TOTAL PRICE F.O.B. DESTINATION:      \$129,884.00**

**VO-260-I (Chipper/Forestry) STANDARD OPTIONS**

Platform Tilt .....	\$ 374.00
24" x 30" Platform .....	\$ 178.00
Liner & Cover for 24" x 30" Platform.....	\$ 257.00
Hydraulic Tool Power at Rear (Requires 2-speed throttle) .....	\$ 360.00
Outrigger Boom Interlock .....	\$ 925.00
Emergency Power .....	\$ 460.00
Chock Block Holders .....	\$ 160.00
Flood Light .....	\$ 616.00
Strobe .....	\$ 418.00
Back Up Alarm .....	\$ 197.00
Pintle & Plug .....	\$ 730.00
Unitrol Single Stick .....	\$ 430.00
Automatic Transmission-International .....	\$6,250.00

**COLOR BROCHURES AVAILABLE UPON REQUEST  
OR VISIT TIME ON THE WEB AT:  
[WWW.VERSALIFT.COM](http://WWW.VERSALIFT.COM)**



## VO-350-MHI

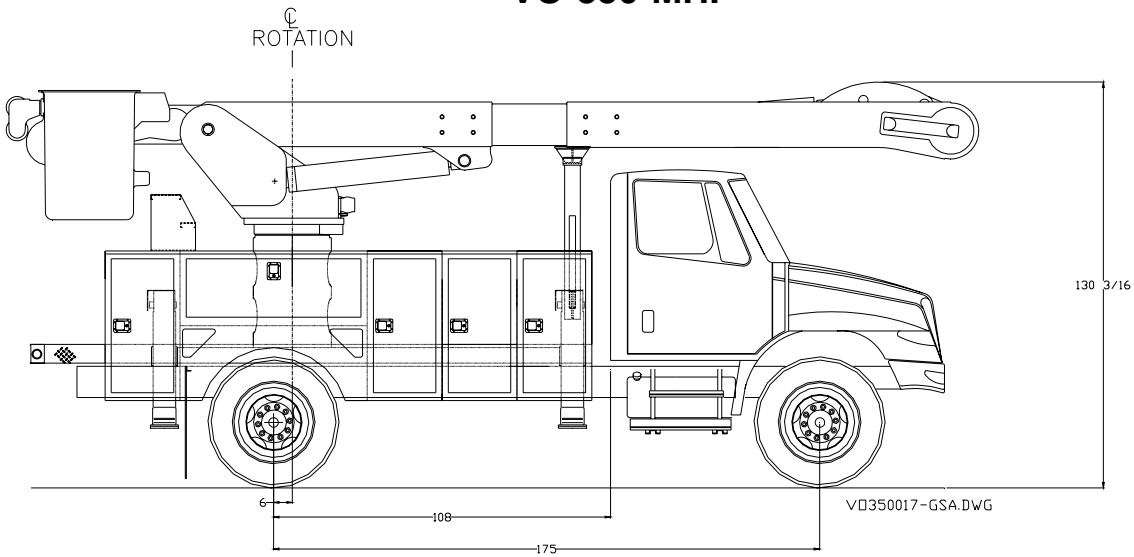

**Versalift Model No. VO-350-MHI**

**Description:** Insulated, 50 ft. (15.2 m) overcenter, articulated aerial platform lift, including 300 lb. platform capacity for each platform.

**Chassis Model INTERNATIONAL 4300 4X2**

**Description:** 33,000 lb. GVWR cab and chassis with 108 inch cab to axle, six (6) speed manual transmission, MaxxForce diesel engine, AM/FM radio, and air conditioning.

**Body Model STEEL SERVICE BODY**

**Description:** 156 inch steel line body with standard compartments, treadplate tops and floor, and 24" tailshelf.

**Installed Items INSTALLATION**

**Description:** Install Versalift VO-350-MHI and line body on chassis. Installation also includes PTO and pump, dual A-frame outriggers, and painting body to match chassis.

**COMPLETE TOTAL PRICE F.O.B. DESTINATION: \$150,770.00**

**VO-350-MHI STANDARD OPTIONS**

Hydraulic Tool Power at Rear (Requires 2-speed throttle) .....	\$ 360.00
Outrigger Boom Interlock, Main & Aux. ....	\$1,550.00
Emergency Power .....	\$ 460.00
Central Locking .....	\$ 280.00
Chock Block Holders .....	\$ 160.00
Compartment Lighting .....	\$ 720.00
Flood Light .....	\$ 616.00
Strobe .....	\$ 418.00
Back Up Alarm .....	\$ 197.00
Pintle & Plug .....	\$ 730.00
Automatic Transmission-International .....	\$6,250.00

**COLOR BROCHURES AVAILABLE UPON REQUEST  
OR VISIT TIME ON THE WEB AT:  
[WWW.VERSALIFT.COM](http://WWW.VERSALIFT.COM)**

### VO-355-MHI

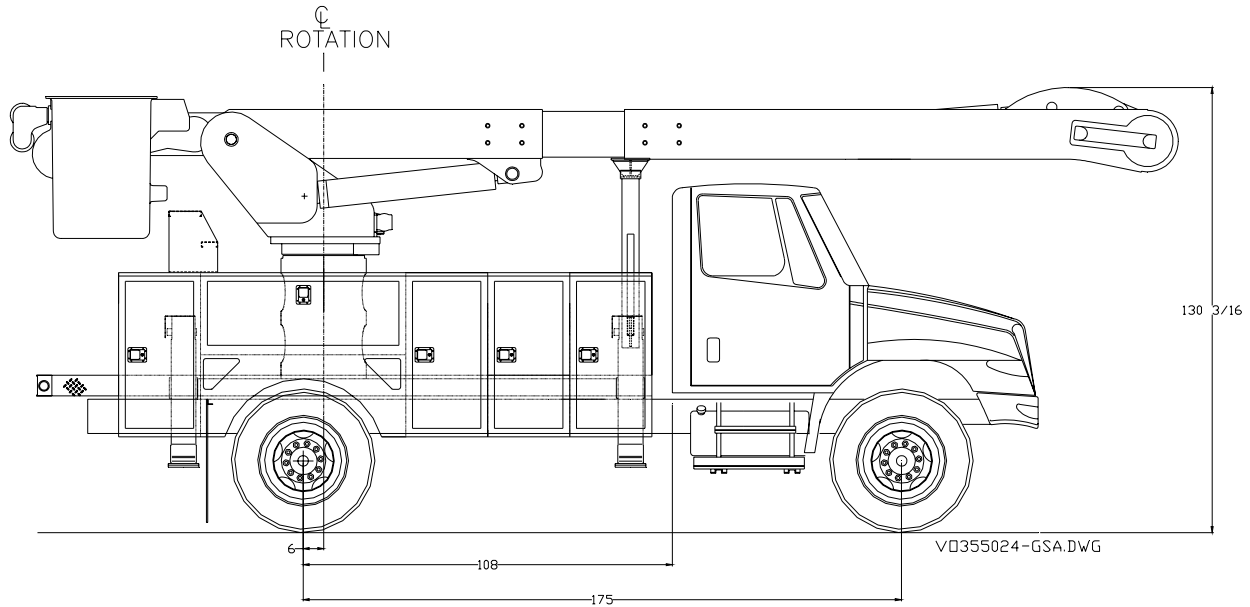

*Versalift Model No.*      **VO-355-MHI**

*Description:*              Insulated, 55 ft. (16.8 m) overcenter, articulated aerial platform lift, including 300 lb. platform capacity for each platform.

*Chassis Model*              **INTERNATIONAL 4300 4X2**

*Description:*              33,000 lb. GVWR cab and chassis with 108 inch cab to axle, six (6) speed manual transmission, MaxxFforce diesel engine, AM/FM radio, and air conditioning.

*Body Model*                 **STEEL SERVICE BODY**

*Description:*              156 inch steel line body with standard compartments, treadplate tops and floor, and 24" tailshelf.

*Installed Items*            **INSTALLATION**

*Description:*              Install Versalift VO-355-MHI and line body on chassis. Installation also includes PTO and pump, dual A-frame outriggers, and painting body to match chassis.

<b>COMPLETE TOTAL PRICE F.O.B. DESTINATION:</b>	<b>\$152,169.00</b>
-------------------------------------------------	---------------------

**VO-355-MHI STANDARD OPTIONS**

Hydraulic Tool Power at Rear (Requires 2-speed throttle) .....	\$ 360.00
Outrigger Boom Interlock, Main & Aux. ....	\$1,550.00
Emergency Power .....	\$ 460.00
Central Locking .....	\$ 280.00
Chock Block Holders .....	\$ 160.00
Compartment Lighting .....	\$ 720.00
Flood Light .....	\$ 616.00
Strobe .....	\$ 418.00
Back Up Alarm .....	\$ 197.00
Pintle & Plug .....	\$ 730.00
Automatic Transmission-International .....	\$6,250.00

**COLOR BROCHURES AVAILABLE UPON REQUEST  
OR VISIT TIME ON THE WEB AT:  
[WWW.VERSALIFT.COM](http://WWW.VERSALIFT.COM)**